

# TEAMFORCE

Another Quality Product by  
**TEAMFORCE**  
ENGINEERING

## CABLE CLEATS

Nylon Cable Cleats are specially design to withstand the high mechanical bursting forces often associated with fault current encountered in cable installation. The cleats are supplied in either Nylon or Nylon Flame Retardant, Halogen free for more environmental friendly.

Fixing of single cable with cable outer diameter ranging from 19mm to 134mm. Trefoil configuration cleats are also available ranging from 3 x 30mm to 3 x 134mm.

Mounting will be done easily on all type of channel. Strut channel mounting with a spring loaded nut as a reversible locking washer offer a choice of fixed or flexible position and direction.

### Nylon (V2)

- UV Resistance.
- Chemical/Corrosion resistant.
- UL-94 flame class V-2.
- High impact resistance.
- Heat distortion temperature 220°C.

### Nylon Flame Retardant (V0)

- UV Resistance.
- UL-94 flame class V-0.
- Chemical/Corrosion resistant.
- High impact resistance.
- Heat distortion temperature 209°C.
- Halogen-free.

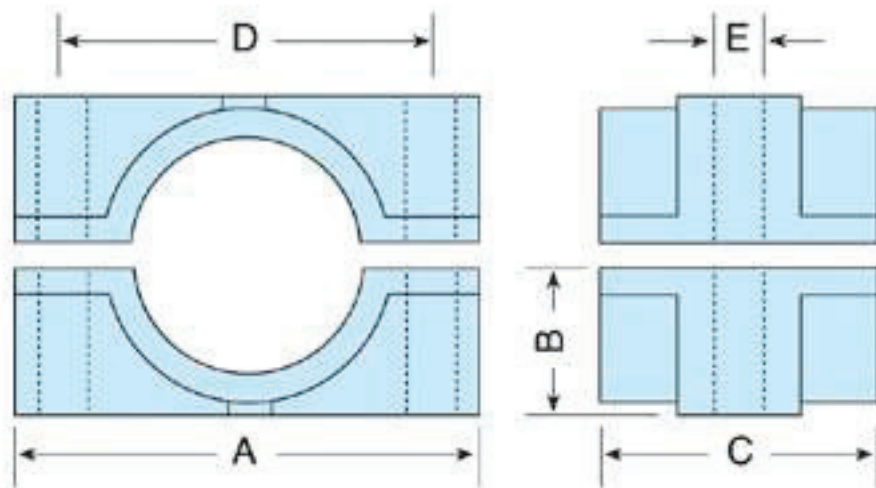

Sizes Available For Two Hole Cable Cleats On Single Cable.

Cat. No.	Cable Dia.	Std. Pack	Dimensions				
			A	B	C	D	E
TF1923	19-23	12 sets	55	15	25	39	7
TF2428	24-28	12 sets	61	18	25	45	7
TF2935	29-35	12 sets	68	21	30	53	7
TF3644	36-44	12 sets	76	24	30	61	7
TF4554	45-54	12 sets	102	32	60	80	11
TF5569	55-69	12 sets	113	36	65	92	11
TF7083	70-83	6 sets	133	45	70	112	14
TF84106	84-106	6 sets	157	55	75	135	14
TF107116	107-116	6 sets	190	63	75	158	14
TF117134	117-134	6 sets	204	73	100	172	14