

Lightning Protection and Earthing Expert

THE COMPANY



Lightning Protection & Earthing Products

Founded by Mr. Steve Yeo in Singapore back 1978, Unitech has been a world recognized brand in the industry with a global distribution network of more than 25 countries. All through the years, Unitech has been widely known of its uncompromising quality, complete product range and knowledgeable technical supports.

Unitech is one of the few brands in the industry that has its own in-house earth rod manufacturing tested to comply with major international standard requirements such as UL467 and BS6651. Other major components of the lightning protection and earthing system are also tested to standards like BS1432, BS6746, BS2874, BS6651, BS7430, BS1400, BS2898 and BS EN 1982.

Some of the Unitech products are original and designed to suit the purposes of users. Its R&D team is committed to serving and satisfying contractors and consultants best in the industry as before.

Unitech products are available in all regions through selected professional distributors who can provide their best service to customers from ready-to-deliver stocks to a full range of technical supports including product knowledge, system design as well as on-site supervision.

Significantly, Unitech's in-house cost effective manufacturing assures a competitive pricing to accommodate every budget resulting in considerable savings to customers.



JOB REFERENCES



GLOBAL DISTRIBUTION NETWORK



COMPLIED STANDARDS & TEST REPORTS

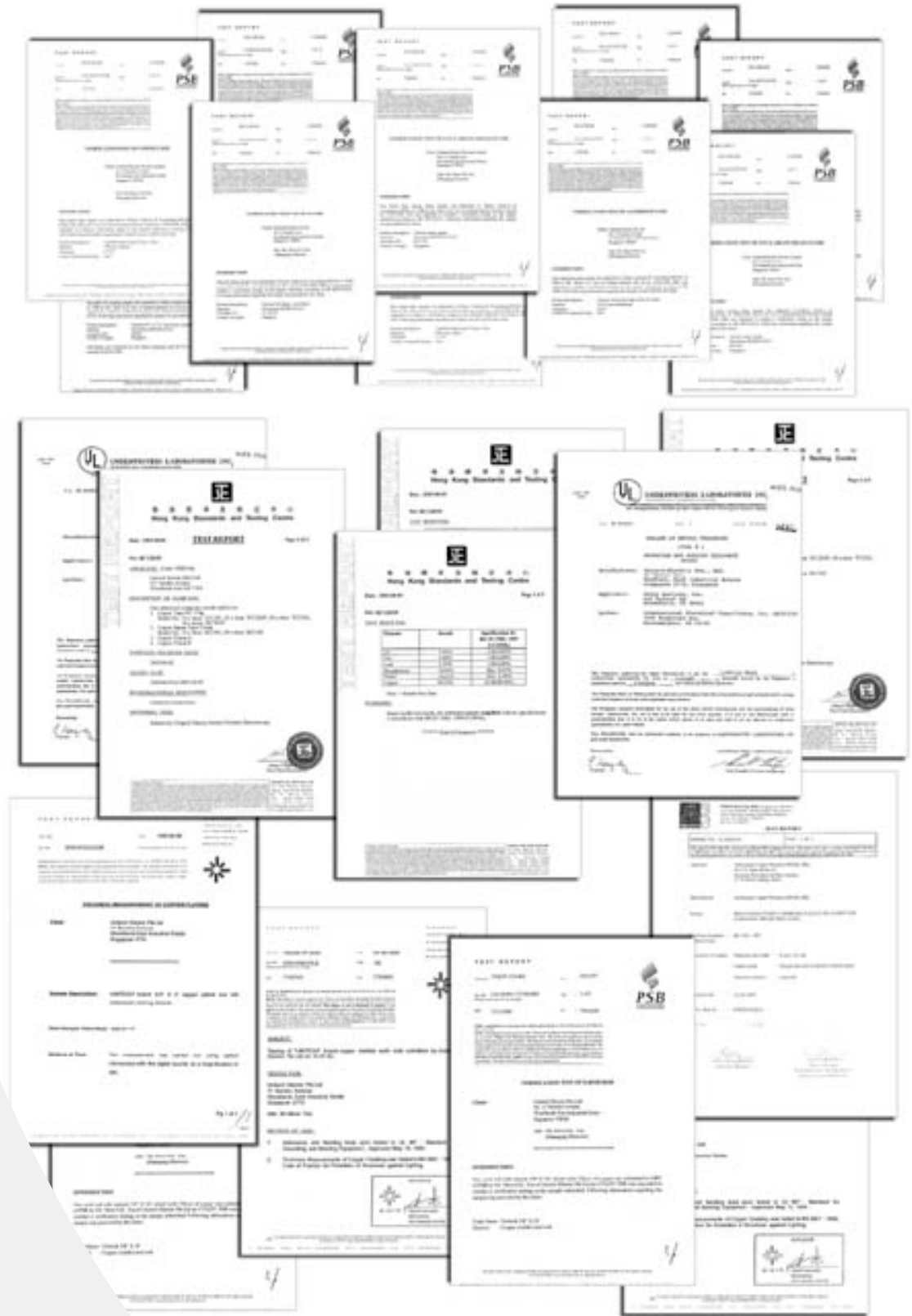

PRODUCT FAMILY

Unitech®



BSi

NFC

LIGHTNING PROTECTION & EARTHING

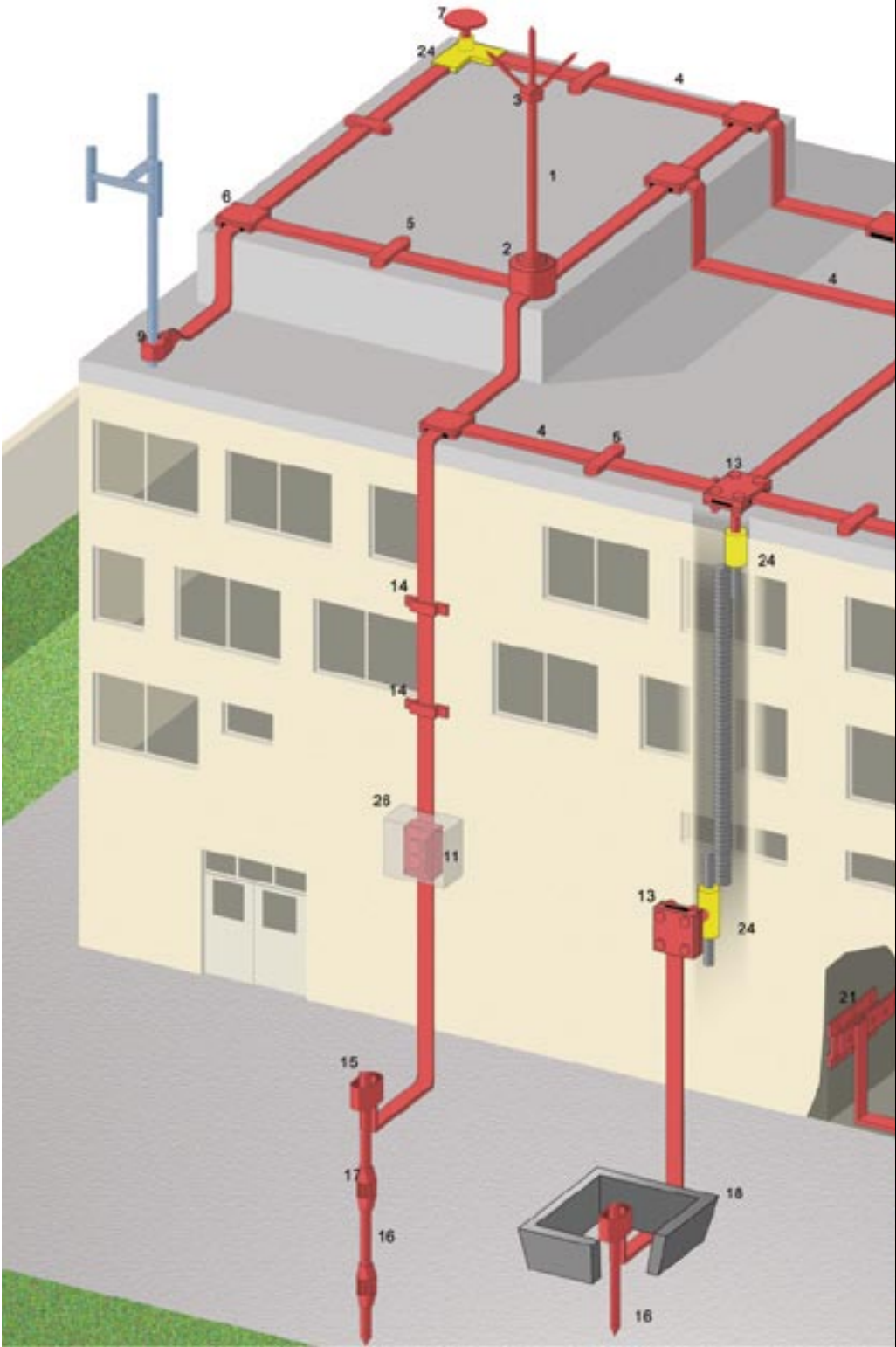

Unitech® Applications Guide

Index

1. Air Rod	14. Light D.C. Clip
2. Air Rod Base	15. Rod to Tape Clamp
3. Multiple Point	16. Earth Rod
4. Copper Tape	17. Coupling
5. D.C. Clip	18. Inspection Pit
6. Square Clamp	19. Solid Copper Earth Plate
7. Strike Pad	20. Copper Tape Earth Mat
8. Adhesive D.C. Clip	21. Earth Disconnecting Link
9. RWP Bond	22. Flexible Copper Braid Bond
10. Bimetallic Connector	23. "SAE" Conducrete
11. Oblong Test or Junction Clamp	24. "thermOweld" Connection
12. Cross Junction Clamp	25. Aluminium Tape
13. Earth Point Welded to Steel Rod	26. Junction Box

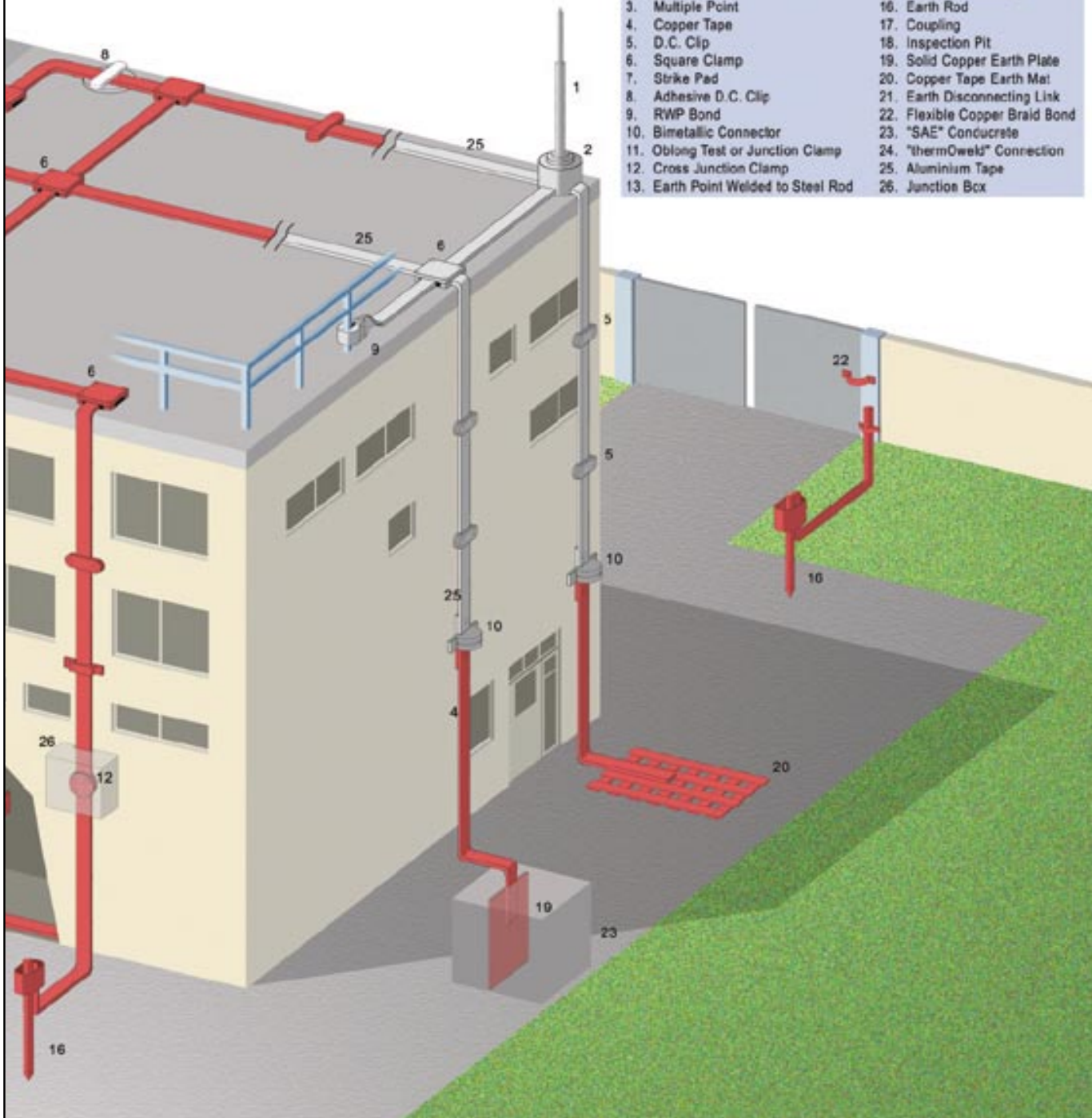

CONTENTS

PAGE

LIGHTNING PROTECTION

⚡ Air Rod	3
⚡ Air Rod Accessories	4
⚡ Conductor	6
⚡ Conductor Accessories	9

EARTHING

⚡ Earth Rod	17
⚡ Bond & Clamp	18
⚡ Earth Plate & Pit	24
⚡ Water Sealing Gland	25
⚡ Earth Point	26
⚡ Earthing Terminal & Accessoires	28
⚡ Conductive Concrete	29
⚡ Equipment	30

EXOTHERMIC WELDING

31

SURGE PROTECTOR

37

LIGHTNING PROTECTION

Lightning Protection Designs

In accordance to BS6651, an effective lightning protection system should consist of the followings:

1. Air terminal network
2. Bonding (Side Strike Protection)
3. Down conductor
4. Earthing

1. Air Terminal Network

Height of building	Size of air terminal mesh needed
Lower than 20m	20m x 10m
Higher than 20m (High risk buildings)	10m x 5m

Following is an illustration of a conventional air terminal mesh design for low structure:

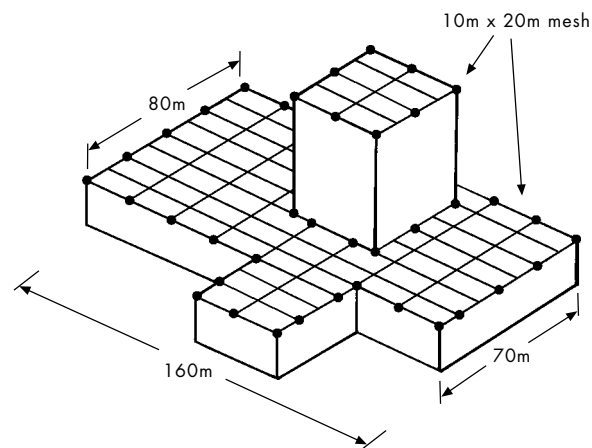

For tall structures (higher than 20m) and buildings with highly explosive or inflammable content, the zone of protection is determined by the Rolling Sphere Method. An imaginary sphere of 20m to 60m in radius is used to roll along the external walls and rooftops of the structure to determine the position, height and number of air terminals required to adequately protect them from lightning strikes.

Zone of Protection

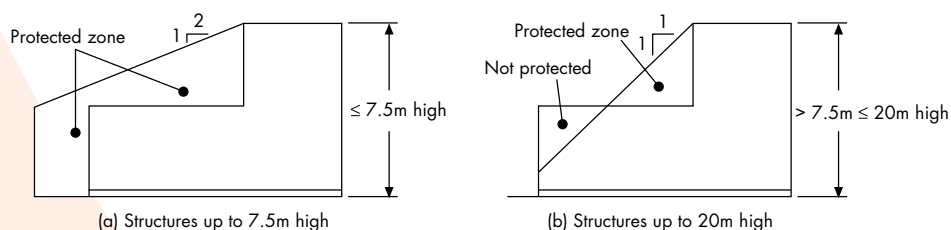

LIGHTNING PROTECTION

Zone of Protection

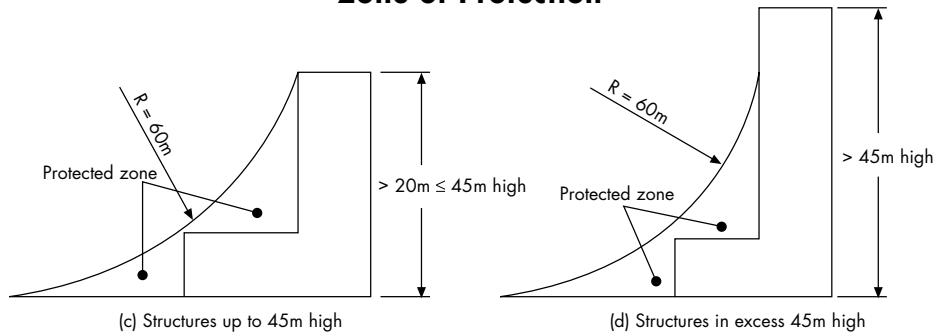

2. Bonding (Side Strike Protection)

To avoid danger from side flashing of lightning, proper bondings to all metal works are necessary. The bondings could be done by connecting water and gas pipes, window and door frames, gates and fencing, air conditioning, staircases and structural steelwork to the system.

3. Down Conductor

For structure lower than 20m, conductors should be evenly spaced with no more than 20m distance apart from each other.

For structure higher than 20m and high-risk buildings, conductors should be evenly spaced with no more than 10m distance apart from each other.

Down conductors should connect directly from air terminal networks to the earth terminations. BS6651 allows the use of the structural steelwork of the structure as down conductors provided that they connect the air terminal networks directly to the earth terminations.

4. Earthing

Down conductors should have their own earth terminations. Test or junction clamps should be used for disconnection from the earth for regular testing. The resistance to earth on each down conductor should be monitored regularly to ensure that it is less than ten times the number of down conductors in the whole lightning protection system (for example, less than 100 ohms for a system with 10 down conductors).

The earthing depth of grounding earth rods of a lightning protection system is determined by soil condition. Earth rods must be spaced at least equal to their earthing depths from one another.

High resistivity soil conditions could be controlled by using suitable conductive concrete for earthing purposes.

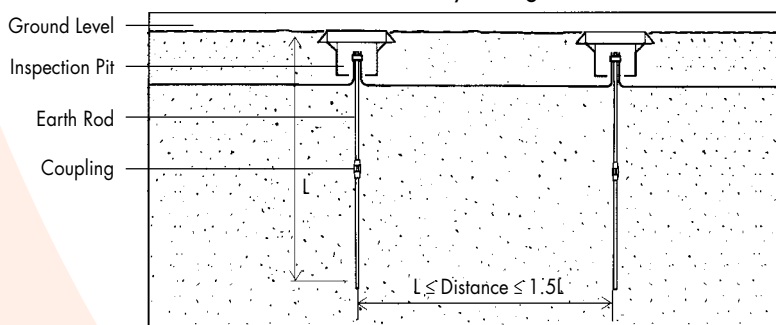

Spacing of Parallel Earth Rod Electrodes

BS6651 also specifies that a lightning protection system should be regularly tested and maintained. Corrosion impairs the effectiveness of the system turning it into an unattractive high impedance path for lightning current to flow.

LIGHTNING PROTECTION

AIR ROD

Multiple Point

Rod Dia	Thread Dia	Material	Part No
15mm	16mm	Copper	MP15
15mm	16mm	Aluminium	MP15A
15mm	16mm	Tinned Copper	MP15T



Solid and Tinned Copper Air Rod

Rod Length	Rod Dia	Thread Dia	Material	Part No
500mm	15mm	16mm	Copper	AR0515
1000mm	15mm	16mm	Copper	AR1015
1500mm	15mm	16mm	Copper	AR1515
2000mm	15mm	16mm	Copper	AR2015
500mm	15mm	16mm	Tinned Copper	AR0515T
1000mm	15mm	16mm	Tinned Copper	AR1015T
1500mm	15mm	16mm	Tinned Copper	AR1515T
2000mm	15mm	16mm	Tinned Copper	AR2015T
500mm	15mm	16mm	Aluminium	AR0515A
1000mm	15mm	16mm	Aluminium	AR1015A
1500mm	15mm	16mm	Aluminium	AR1515A
2000mm	15mm	16mm	Aluminium	AR2015A
500mm	10mm	10mm	Copper	AR0510
1000mm	10mm	10mm	Copper	AR1010
500mm	10mm	10mm	Aluminium	AR0510A
1000mm	10mm	10mm	Aluminium	AR1010A

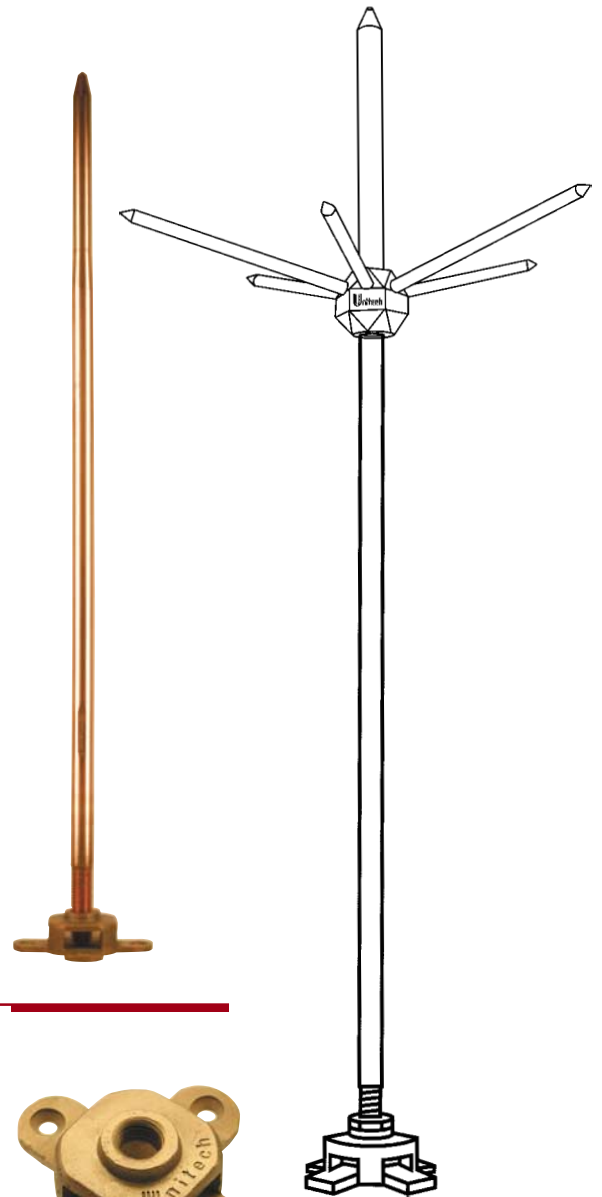

Copperbond Air Rod

Rod Length	Rod Dia	Thread Dia	Part No
500mm	15mm	16mm	AR0515CB
1000mm	15mm	16mm	AR1015CB
1500mm	15mm	16mm	AR1515CB
2000mm	15mm	16mm	AR2015CB



Air Rod Base

(For Copper Tape Use)

Rod Dia	Thread Dia	Material	Part No
15mm	16mm	Copper	ARB15
15mm	16mm	Aluminium	ARB15A
15mm	16mm	Tinned Copper	ARB15T



LIGHTNING PROTECTION

AIR ROD ACCESSORIES

Air Rod Base (Vertically Mounted)

(For 8mm Dia Conductor Use)

Conductor Dia	Thread Dia	Material	Part No
8mm	10mm	Copper	ARBV8
8mm	10mm	Aluminium	ARBV8A
8mm	10mm	Tinned Copper	ARBV8T

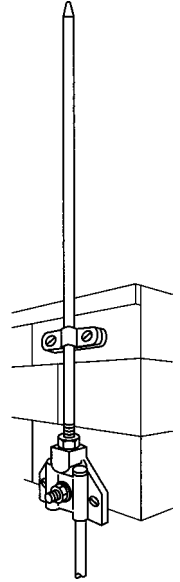

Air Rod Base (Horizontally Mounted)

(For 8mm Dia Conductor Use)

Conductor Dia	Thread Dia	Material	Part No
8mm	10mm	Copper	ARBH8
8mm	10mm	Aluminium	ARBH8A
8mm	10mm	Tinned Copper	ARBH8T

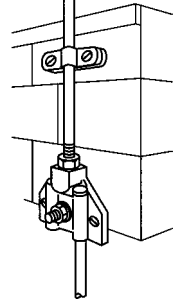

Aluminium Air Rod Base

Rod Dia	Conductor Size	Part No
15mm	25x3mm	ARBF15A

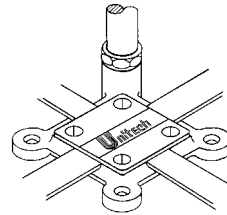

Ridge Air Rod Base

Rod Dia	Thread Dia	Material	Part No
15mm	16mm	Copper	ARS15
15mm	16mm	Aluminium	ARS15A
15mm	16mm	Tinned Copper	ARS15T

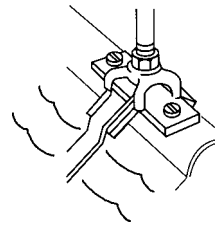

Air Rod Bracket

Rod Dia	Thread Dia	Material	Part No
15mm	16mm	Copper	ARK15
15mm	16mm	Aluminium	ARK15A
15mm	16mm	Tinned Copper	ARK15T

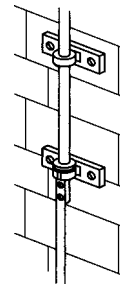

LIGHTNING PROTECTION

AIR ROD ACCESSORIES

Rod to Tape/Cable Coupling

(For Rod Brackets Use)

Rod Dia	Thread Dia	Cable Size	Material	Part No
15mm	16mm	-	Copper	RTCC15
15mm	16mm	-	Aluminium	RTCC15A
15mm	16mm	-	Tinned Copper	RTCC15T
15mm	16mm	50mm ²	Copper	RTCC50
15mm	16mm	70mm ²	Copper	RTCC70
15mm	16mm	95mm ²	Copper	RTCC95

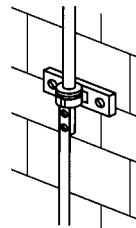

Rod to Tape

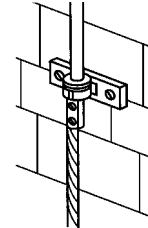

Rod to Cable



Strike Pad with Copper Stem

Rod Dia	Length	Material	Part No
10mm	60mm	Copper	SPWS10
10mm	60mm	Aluminium	SPWS10A
10mm	60mm	Tinned Copper	SPWS10T

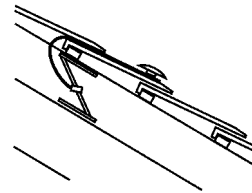

Strike Pad welded to Bar/Tape

Material	Part No
Copper	SP10W
Aluminium	SP10AW
Tinned Copper	SP10WT

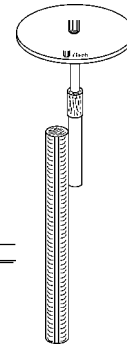
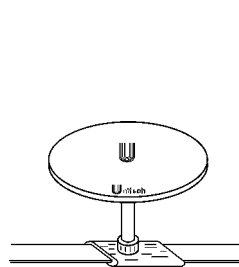

Puddle Flange

Plate Size	Material	Part No
150x150x3mm ³	Copper	PF10
150x150x3mm ³	Aluminium	PF10A
150x150x3mm ³	Tinned Copper	PF10T

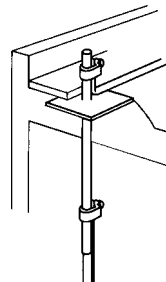

LIGHTNING PROTECTION

CONDUCTOR

Bare and Tinned Copper Tape

Copper tape to BS1432

Conductor Size	Part No (Bare)	Part No (Tinned)
12.5x1.5mm	CT121	CT121T
12.5x3mm	CT123	CT123T
20x1.5mm	CT201	CT201T
20x3mm	CT203	CT203T
25x1.5mm	CT251	CT251T
25x3mm	CT253	CT253T
25x4mm	CT254	CT254T
25x6mm	CT256	CT256T
31x3mm	CT313	CT313T
31x6mm	CT316	CT316T
38x3mm	CT383	CT383T
38x5mm	CT385	CT385T
38x6mm	CT386	CT386T
40x4mm	CT404	CT404T
40x6mm	CT406	CT406T
50x3mm	CT503	CT503T
50x4mm	CT504	CT504T
50x6mm	CT506	CT506T



Bare



Tinned







LSF and PVC Covered Copper Tape

PVC Colours to BS5252

Conductor Size	Colour Range	Part No (LSF)	Part No (PVC)
25x3mm	Green	CT253LS-GN	CT253P-GN
25x3mm	Grey	CT253LS-GR	CT253P-GR
25x3mm	White	CT253LS-WE	CT253P-WE
25x6mm	Green	CT256LS-GN	CT256P-GN
25x6mm	Grey	CT256LS-GR	CT256P-GR
25x6mm	White	CT256LS-WE	CT256P-WE
38x6mm	Green	CT386LS-GN	CT386P-GN
38x6mm	Grey	CT386LS-GR	CT386P-GR
38x6mm	White	CT386LS-WE	CT386P-WE
50x6mm	Green	CT506LS-GN	CT506P-GN
50x6mm	Grey	CT506LS-GR	CT506P-GR
50x6mm	White	CT506LS-WE	CT506P-WE



LSF and PVC Conductor Colour Chart

Black (BK)	18B29*	
Green (GN)	BS 6746C	
Grey (GR)	00A07*	
Stone (SE)	08B23*	
White (WE)	10B15*	
Brown (BW)	06C39*	

* PVC colours to BS 5252 All colours available on request

LIGHTNING PROTECTION

CONDUCTOR

Green & Yellow PVC Insulated Copper Tape

Conductor Size	Part No
25x3mm	CT253P-GY
25x6mm	CT256P-GY

* PVC Colours to BS6746C



Lead Covered Copper Tape

Conductor Size	Part No
25x3mm	CT253L
25x6mm	CT256L
50x6mm	CT506L



Bare and Tinned Hard Drawn Copper Bar

Copper Bar to BS2874

Conductor Size	Part No (Bare)	Part No (Tinned)
25x3mm	CT253H	CT253HT
25x6mm	CT256H	CT256HT
38x6mm	CT386H	CT386HT
50x6mm	CT506H	CT506HT
50x10mm	CT5010H	CT5010HT
75x6mm	CT756H	CT756HT
100x6mm	CT1006H	CT1006HT



Bare and Tinned Flexible Copper Braid

Copper Braid to BS4109

Nominal Size	Part No (Bare)	Part No (Tinned)
12x1mm	FCB121	FCB121T
15x1.5mm	FCB151	FCB151T
19x2.5mm	FCB192	FCB192T
25x3.5mm	FCB253	FCB253T
32x6mm	FCB326	FCB326T



Bare and PVC covered Aluminium Tape

Aluminium tape to BS2898-1350

Conductor Size	Part No (Bare)	Part No (PVC)
20x3mm	CT203A	CT203AP
25x3mm	CT253A	CT253AP
25x6mm	CT256A	CT256AP

* PVC Colours to BS5252 available on request.
Please refer to page 4 colour chart.



LIGHTNING PROTECTION

CONDUCTOR

Bare and PVC Covered Solid Circular Conductor

Copper Conductor to BS1433

Diameter	Cross-sectional Area	Conductor Material	Part No (Solid)	Part No (PVC)
8mm	50.27mm ²	Copper	CC8	CC8P
8mm	50.27mm ²	Tinned Copper	CC8T	-



Bare Stranded Copper Conductor

Soft Drawn Stranded Copper Conductor to BS 6360

Cross-sectional Area	Stranding No/mmØ	Part No
6mm ²	7/1.04	SCC06
16mm ²	7/1.70	SCC16
25mm ²	7/2.14	SCC25
35mm ²	7/2.52	SCC35
50mm ²	19/1.78	SCC50
70mm ²	19/2.14	SCC70
95mm ²	19/2.52	SCC95
120mm ²	37/2.03	SCC120
150mm ²	37/2.25	SCC150
185mm ²	37/2.52	SCC185
240mm ²	61/2.25	SCC240
300mm ²	61/2.52	SCC300



PVC Covered Stranded Copper Conductor

PVC Colour to BS 6746C

Size	Stranding No/mmØ	Part No
6mm ²	7/1.04	SCC06P
16mm ²	7/1.70	SCC16P
25mm ²	7/2.14	SCC25P
35mm ²	7/2.52	SCC35P
50mm ²	19/1.78	SCC50P
70mm ²	19/2.14	SCC70P
95mm ²	19/2.52	SCC95P
120mm ²	37/2.03	SCC120P
150mm ²	37/2.25	SCC150P
185mm ²	37/2.52	SCC185P
240mm ²	61/2.25	SCC240P
300mm ²	61/2.52	SCC300P



LIGHTNING PROTECTION

CONDUCTOR ACCESSORIES

Bare and Tinned DC Clip (Gunmetal to BS1400)

(For Tinned or Bare Copper Tape)

Conductor Size	Part No (Bare)	Part No (Tinned)
12.5x1.5mm	DC121	DC121T
12.5x3mm	DC123	DC123T
20x1.5mm	DC201	DC201T
20x3mm	DC203	DC203T
25x1.5mm	DC251	DC251T
25x3mm	DC253	DC253T
25x4mm	DC254	DC254T
25x6mm	DC256	DC256T
31x3mm	DC313	DC313T
31x6mm	DC316	DC316T
38x3mm	DC383	DC383T
38x5mm	DC385	DC385T
38x6mm	DC386	DC386T
40x4mm	DC404	DC404T
40x6mm	DC406	DC406T
50x3mm	DC503	DC503T
50x4mm	DC504	DC504T
50x6mm	DC506	DC506T

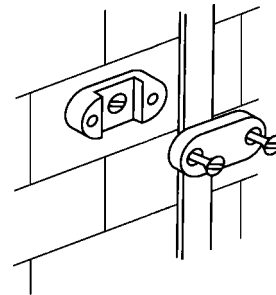

Bare
50x6mm



Tinned
25x3mm



Bare
25x6mm

Bare and Tinned DC Clip (Gunmetal to BS1400)

(For PVC Covered Copper Tape)

Conductor Size	Part No (Bare)	Part No (Tinned)
25x3mm	DC253P	DC253TP
25x6mm	DC256P	DC256TP
38x6mm	DC386P	DC386TP
50x6mm	DC506P	DC506TP

For 25x3mm
PVC Tape



For 25x6mm
PVC Tape

Tinned DC Clip (Gunmetal to BS1400)

(For Lead Covered Copper Tape)

Conductor Size	Part No
25x3mm	DC253TL
25x6mm	DC256TL
50x6mm	DC506TL



Aluminium DC Clip to BS1490

(For Bare & PVC Covered Aluminium Tape)

Conductor Size	Part No (Bare)	Part No (PVC)
25x3mm	DC253A	DC253AP
25x6mm	DC256A	DC256AP



LIGHTNING PROTECTION

CONDUCTOR ACCESSORIES

Light DC Clip

(For Copper, Tinned Copper and Aluminium Tape)

Conductor Size	Material	Part No
20x3mm	Copper	LDC203
20x3mm	Tinned Copper	LDC203T
20x3mm	Aluminium	LDC203A
25x3mm	Copper	LDC253
25x3mm	Tinned Copper	LDC253T
25x3mm	Aluminium	LDC253A

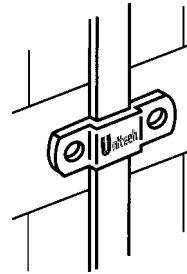

Non-metallic DC Clip

(For Bare Copper Tape)

Conductor Size	Colour	Part No
20x3mm	Brown	DC203N-BN
20x3mm	Grey	DC203N-GR
25x3mm	Brown	DC253N-BN
25x3mm	Grey	DC253N-GR

* Other PVC Colours to BS5252 available on request.
Please refer to page 4 colour chart.

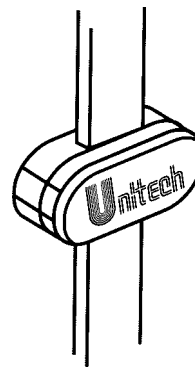

PVC and LSF Non-metallic DC Clip

(For PVC and LSF Covered Copper Tape)

Conductor Size	Colour	Part No (PVC)	Part No (LSF)
25x3mm	Green	DC253NP-GN	DC253LS-GN
25x3mm	Grey	DC253NP-GR	DC253LS-GR
25x3mm	White	DC253NP-WE	DC253LS-WE
25x3mm	Black	DC253NP-BK	DC253LS-BK
25x3mm	Brown	DC253NP-BW	DC253LS-BW

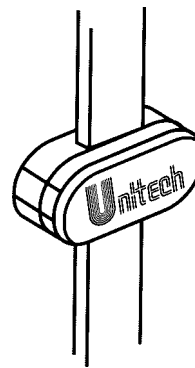

Adhesive DC Clip

(For Bare Copper Tape)

Conductor Size	Colour	Part No
25x3mm	Grey	ADC253-GR
25x3mm	Brown	ADC253-BW
25x3mm	White	ADC253-WE
25x3mm	Green	ADC253-GN

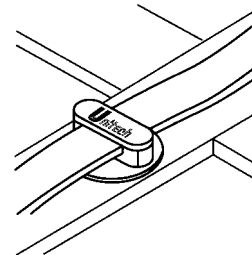

Adhesive LSF DC Clip

(For PVC and LSF Covered Copper Tape)

Conductor Size	Colour	Part No
25x3mm	Green	ADC253LS-GN
25x3mm	Grey	ADC253LS-GR
25x3mm	White	ADC253LS-WE
25x3mm	Black	ADC253LS-BK
25x3mm	Brown	ADC253LS-BW

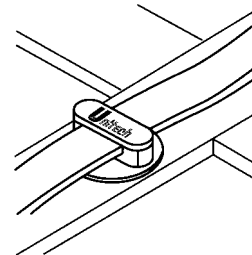

LIGHTNING PROTECTION

CONDUCTOR ACCESSORIES

Bare and Tinned Square Clamp (Gunmetal to BS1400)

(For Bare and Tinned Copper Tape)

Conductor Size	Part No (Bare)	Part No (Tinned)
25x3mm	SC253	SC253T
25x6mm	SC256	SC256T
31x3mm	SC313	SC313T
31x6mm	SC316	SC316T
38x6mm	SC386	SC386T
50x6mm	SC506	SC506T

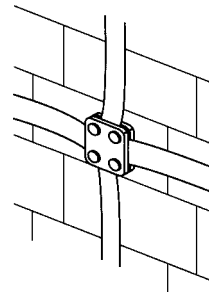

Tinned Square Clamp (Gunmetal to BS1400)

(For Lead Covered Copper Tape)

Conductor Size	Part No
25x3mm	SC253TL
25x6mm	SC256TL
50x6mm	SC506TL



Aluminium Square Clamp to BS1490

Conductor Size	Part No
25x3mm	SC253A
25x6mm	SC256A



Oblong Test or Junction Clamp with Junction Box (Gunmetal to BS1400)

Conductor Size	Part No (Bare)	Part No (Tinned)
25x3mm	JC253	JC253T
25x6mm	JC256	JC256T
31x3mm	JC313	JC313T
38x6mm	JC386	JC386T
50x6mm	JC506	JC506T
* Part no. of junction box		JB10SS

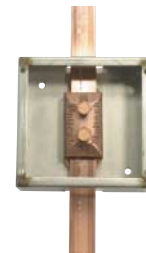
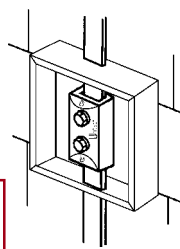

Cross Junction Clamp (Gunmetal to BS1400)

Conductor Size	Material	Part No
25x3mm	Copper	CJC253
25x3mm	Aluminium	CJC253A

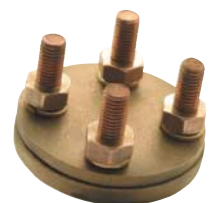
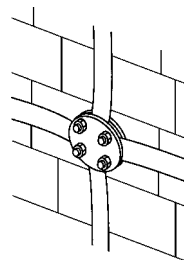

LIGHTNING PROTECTION

CONDUCTOR ACCESSORIES

Bimetallic Connector

Conductor Size	Part No
25x3mm Aluminium Tape to 25x3mm Copper Tape	BMC253
8mm Aluminium Conductor to 8mm Copper conductor	BMC8

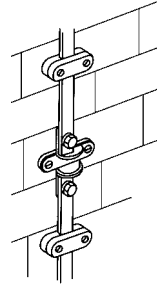

Back Plate Holdfast Stem

Material	Part No
Copper	BPHS10
Aluminium	BPHS10A

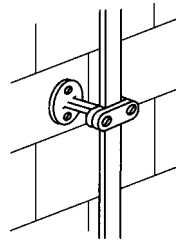

One Hole Cable Clip

Conductor Dia	Conductor Material	Part No
8mm	Copper	OHCC8
8mm	Tinned Copper	OHCC8T
8mm	Aluminium	OHCC8A
10mm	Copper	OHCC10
10mm	Tinned Copper	OHCC10T
10mm	Aluminium	OHCC10A

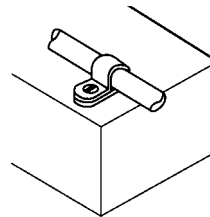

Heavy Duty Cast Cable Saddle

Conductor Dia	Conductor Material	Part No
8mm	Copper	CCS8
8mm	Tinned Copper	CCS8T
8mm	Aluminium	CCS8A
10mm*	Copper	CCS10
10mm*	Tinned Copper	CCS10T
10mm*	Aluminium	CCS10A

*PVC Covered 8mm conductor

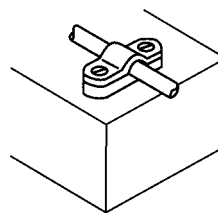

LIGHTNING PROTECTION

CONDUCTOR ACCESSORIES

Glazing Bar Holdfast

Conductor Material	Max. Glazing Bar Width	Part No
Copper	12mm	BH12
Tinned Copper	12mm	BH12T
Aluminium	12mm	BH12A

* To use with DC Clips

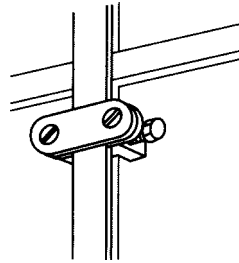

Square Clamp

Conductor Dia	Conductor Material	Part No
8mm	Copper	CSC8
8mm	Tinned Copper	CSC8T
8mm	Aluminium	CSC8A

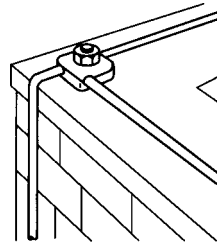

Tee Clamp

Conductor Dia	Conductor Material	Part No
8mm	Copper	CTC8
8mm	Tinned Copper	CTC8T
8mm	Aluminium	CTC8A

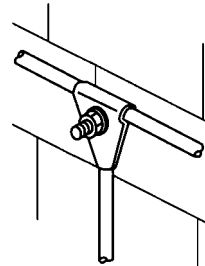

Jointing Clamp

Conductor Dia	Conductor Material	Part No
8mm	Copper	CJC8
8mm	Tinned Copper	CJC8T
8mm	Aluminium	CJC8A

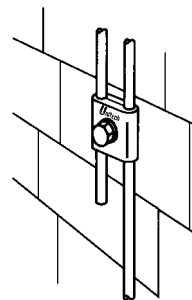

LIGHTNING PROTECTION

CONDUCTOR ACCESSORIES

Test Clamp

Conductor Dia	Conductor Material	Part No
8mm	Copper	CTSC8
8mm	Tinned Copper	CTSC8T
8mm	Aluminium	CTSC8A

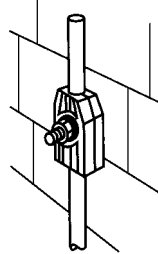

Metalwork Bond

Conductor Dia	Conductor Material	Part No
8mm	Copper	CMB8
8mm	Tinned Copper	CMB8T
8mm	Aluminium	CMB8A

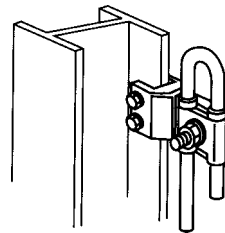

Pipe Bond

Conductor Dia	Pipe Dia	Conductor Material	Part No
8mm	50-300mm	Copper	CPB8
8mm	50-300mm	Tinned Copper	CPB8T
8mm	50-300mm	Aluminium	CPB8A

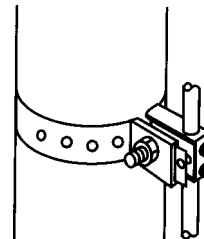

Re-Bar Clamp

Conductor Dia	Pipe Dia	Conductor Material	Part No
8mm	8-20mm	Copper	RBC820
8mm	8-20mm	Tinned Copper	RBC820T
8mm	20-40mm	Copper	RBC204
8mm	20-40mm	Tinned Copper	RBC204T

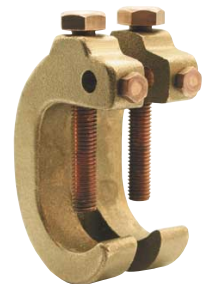
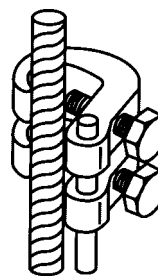

LIGHTNING PROTECTION

CONDUCTOR ACCESSORIES

Straight Conductor Socket

Conductor Dia	Palm Hole Dia	Conductor Material	Part No
8mm	12mm	Copper	SCS8
8mm	12mm	Tinned Copper	SCS8T
8mm	12mm	Aluminium	SCS8A

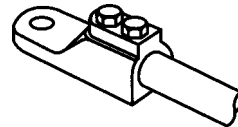

Cable Test Junction Clamp

Conductor Size	Conductor Material	Part No
50mm ²	Copper	CTJC50
70mm ²	Copper	CTJC70
95mm ²	Copper	CTJC95
50mm ²	Tinned Copper	CTJC50T
70mm ²	Tinned Copper	CTJC70T
95mm ²	Tinned Copper	CTJC95T

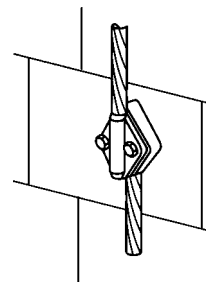

Square Cable Clamp

Conductor Size	Conductor Material	Part No
50mm ²	Copper	SQC50
70mm ²	Copper	SQC70
95mm ²	Copper	SQC95
50mm ²	Tinned Copper	SQC50T
70mm ²	Tinned Copper	SQC70T
95mm ²	Tinned Copper	SQC95T

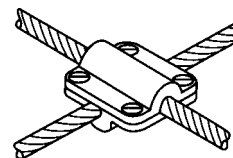

EARTHING



Introduction

An earthing (grounding) system is designed to safeguard lives and valuable equipments when lightning occurs. It plays a vital role in an electrical and lightning protection system. It is installed to:

- remove leakage or stray electricity from unwanted areas
- protect valuable equipments, properties and human lives
- conduct away static electricity from charge bodies
- direct lightning current to the ground through pre-determined paths

The most economical, reliable and widely accepted system is by using an electrode (earth rod). It is made from a strong steel core bonded with a layer of pure copper jacket. This type of electrode provides high mechanical strength, good electrical conductivity and resistance to corrosion. Earth rods with radical thickness of copper of 250 microns have installed service life of 20 to 25 years under normal soil conditions.

UNITECH earth rods comply to international standards including UL467, BS7430 and 6651. They are made from AISI-1018 (SAE 1018) high tensile low carbon steel cores and molecularly bonded with 99.9% pure electrolytic copper jacket to a minimum radial thickness of 250 microns. The strong steel core gives high column strength for deep driving into hard ground while the copper jacket provides good conductivity and long installed service life.

Stainless steel rods can also be used to overcome galvanic corrosion that happens between dissimilar metals buried in close proximity.

UNITECH also tailor-makes solid copper rods. They are required to be used in highly corrosive soil condition and exceptionally long service is necessary.

Earth Rod Fittings



Copperbond Earth Rod

Solid Copper Earth Rod

EARTHING

EARTH ROD

Specification of Unitech Copperbond Earth Rod

Steel Core: Low carbon high tensile steel, AISI-1018 (SAE-1018), UTS = 650 – 680N/mm²

Copper Jacket: 99.9% pure electrolytic

Rod Dia (Nominal)	Rod Dia (Actual)	Fusing Current (Amp)			Equivalent to Copper Conductor mm ²
		1/4 sec	1/2 sec	1 sec	
12.5mm(1/2")	11mm	23,800	16,900	12,000	40
14mm(9/16")	12.5mm	30,000	20,000	15,000	50
16mm(5/8")	14.2mm	38,000	26,900	19,000	70
19mm(3/4")	17.2mm	56,900	40,200	28,400	95
25mm(1")	22.2mm	98,000	68,600	49,000	150

Copperbond Earth Rod

Rod Dia (Nominal)	Length	Rod Dia (Actual)	Part No (Threaded)	Part No (Non-Threaded)
12.5mm(1/2")	1200mm(4")	11mm	B101	NE101
12.5mm(1/2")	1500mm(5")	11mm	B102	NE102
12.5mm(1/2")	1800mm(6")	11mm	B103	NE103
12.5mm(1/2")	2400mm(8")	11mm	B104	NE104
12.5mm(1/2")	3000mm(10")	11mm	B105	NE105
14mm	1200mm(4")	12.5mm	B144	NE144
14mm	1500mm(5")	12.5mm	B145	NE145
14mm	1800mm(6")	12.5mm	B146	NE146
14mm	2100mm(7")	12.5mm	B147	NE147
14mm	2400mm(8")	12.5mm	B148	NE148
14mm	3000mm(10")	12.5mm	B1410	NE1410
16mm(5/8")	1200mm(4")	14.2mm	B201	NE201
16mm(5/8")	1500mm(5")	14.2mm	B202	NE202
16mm(5/8")	1800mm(6")	14.2mm	B203	NE203
16mm(5/8")	2400mm(8")	14.2mm	B204	NE204
16mm(5/8")	3000mm(10")	14.2mm	B205	NE205
19mm(3/4")	1200mm(4")	17.2mm	B301	NE301
19mm(3/4")	1500mm(5")	17.2mm	B302	NE302
19mm(3/4")	1800mm(6")	17.2mm	B303	NE303
19mm(3/4")	2400mm(8")	17.2mm	B304	NE304
19mm(3/4")	3000mm(10")	17.2mm	B305	NE305



* Stainless steel and solid copper earth rods can be supplied on request.

* Special size and copper thickness can be supplied on request.

EARTHING

BOND & CLAMP

Copper Coupling

Nominal Size	Length	Dia	Part No
12.5mm (1/2")	60mm	17mm	CP501
16mm (5/8")	70mm	20.5mm	CP502
19mm (3/4")	70mm	24mm	CP503
14mm	60mm	19mm	CP514

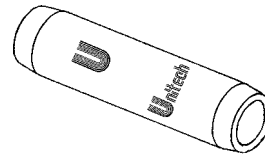

High Tensile Steel Driving Head

For Earth Rod Size	Part No
12.5mm (1/2")	DS80
16mm (5/8")	DS81
19mm (3/4")	DS82
14mm	DS14

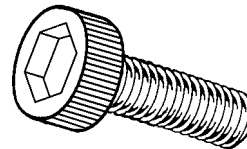

Rod To Tape Clamp (Type A)

Rod Dia	Max. Conductor	Part No
12.5mm(1/2")	26x12mm	RTC10
16mm(5/8")	26x12mm	RTC10
19mm(3/4")	26x10mm	RTC10
16mm(5/8")	40x12mm	RTC30
16mm(5/8")	51x8mm	RTC40
19mm(3/4")	51x12mm	RTC50
12.5mm(1/2")	26x20mm	RTC60
16mm(5/8")	26x18mm	RTC60
19mm(3/4")	26x10mm	RTC60
25mm(1")	26x10mm	RTC60

*Special Size available on request

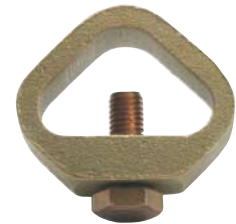

Rod To Cable Clamp (Type B)

Rod Dia	Conductor Range	Part No
9.5mm(3/8")	6-35mm	RCC9
12.5mm(1/2")	16-50mm	RCC12
16mm(5/8")	16-70mm	RCC16
19mm(3/4")	16-95mm	RCC20
25mm(1")	70-120mm	RCC25



EARTHING

BOND & CLAMP

AB Clamp

Rod Dia	Max Conductor	Part No
16mm (5/8")	25mm x 3mm	CLAB 500

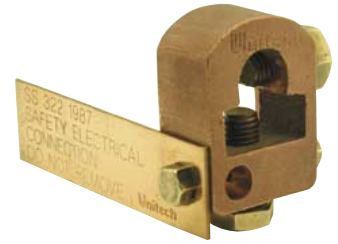
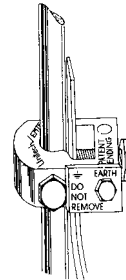
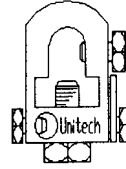

Rod To Cable Lug Clamp

Rod Dia	Rod Type	Part No
9.5mm(3/8")	Copperbond	RCLC9
16mm(5/8")	Copperbond	RCLC16
19mm(3/4")	Copperbond	RCLC20
16mm(5/8")	Solid Copper	RCLC16S
19mm(3/4")	Solid Copper	RCLC20S

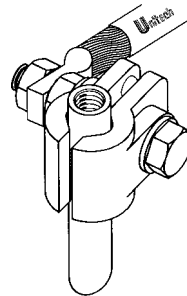

Tower Clamp

Max Conductor Size	Part No
50-70mm ²	TC50
70-95mm ²	TC70

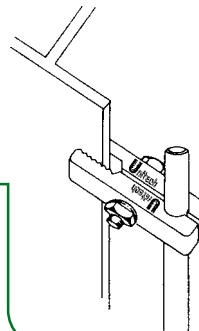

Tinned Copper Bonding Clip

(for water pipe)

Ext. Dia of Water Pipe	Part No
4/8"	BC6
6/8"	BC8
15mm	BC15
48mm	BC48
76mm	BC76

* Other sizes available on request.

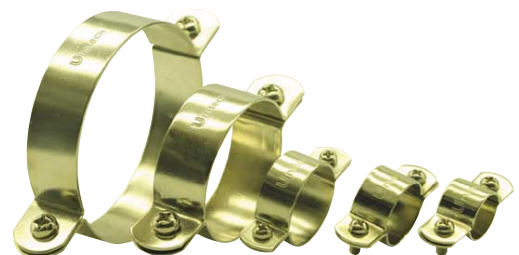

EARTHING

BOND & CLAMP

"U" Bolt Rod Clamp

Rod / Pipe Dia	No. of Conductors	Conductor Size	No. of Copper Tape	Tape Size	Part No
16mm(5/8") - 19mm(3/4")	1	50-95mm ²	-	-	UC301
16mm(5/8") - 19mm(3/4")	2	50-70mm ²	-	-	UC302
16mm(5/8") - 19mm(3/4")	3	50-70mm ²	-	-	UC303
16mm(5/8") - 19mm(3/4")	5	50-70mm ²	-	-	UC304
16mm(5/8") - 19mm(3/4")	3	70-120mm ²	-	-	UC305
16mm(5/8") - 19mm(3/4")	2	50-70mm ²	-	-	UC306
16mm(5/8") - 19mm(3/4")	1	70-120mm ²	-	25mm x 3mm	UC307
16mm(5/8") - 19mm(3/4")	-	-	1 or 2	25mm x 3mm	UC308
30mm	-	-	1 or 2	50mm x 6mm	UC309
40mm	-	-	1	25mm x 3mm	UC310



UC303

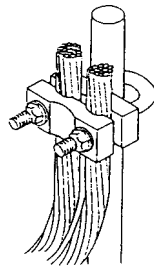

UC302



UC304

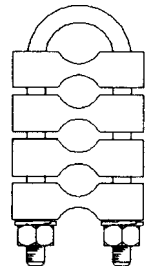
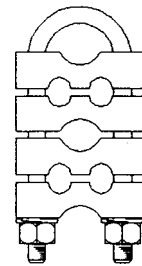

UC305



UC307

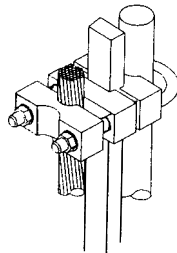

UC301

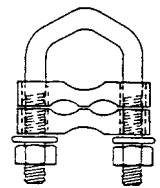
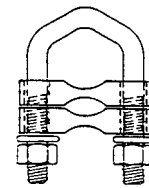

UC302



UC308

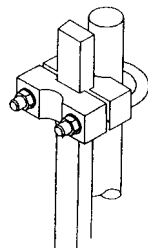

UC310

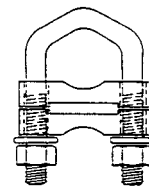

UC308

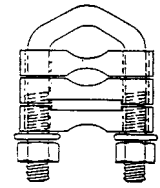

UC307

* Other combinations can be supplied on request.

EARTHING

BOND & CLAMP

"H" Clamp

Rod / Pipe Dia	No. of Conductors	Conductor Size	No. of Copper Tape	Tape Size	Part No
16mm(5/8") - 19mm(3/4")	1	50-95mm ²	-	-	HC401
16mm(5/8") - 19mm(3/4")	1	95-120mm ²	-	-	HC402
16mm(5/8") - 19mm(3/4")	2	50-95mm ²	-	-	HC403
16mm(5/8") - 19mm(3/4")	3	70-95mm ²	-	-	HC404
16mm(5/8") - 19mm(3/4")	1	120-150mm ²	-	-	HC405
16mm(5/8") - 19mm(3/4")	2	70-95mm ²	or	1	25mm x 3mm HCL504
16mm(5/8") - 19mm(3/4")	-	-		1	50mm x 6mm HCL506
16mm(5/8") - 19mm(3/4")	2	6mm		1	50mm x 6mm HCL506S
300mm ²	2	70mm ²	-	-	HCL507
16mm(5/8") - 19mm(3/4")	2	120-150mm ²	-	-	HCL512
16mm(5/8") - 19mm(3/4")	3	120-150mm ²	-	-	HCL513
300mm ²	2 + 1	70mm ² + 150mm ²	-	-	HCL514
300mm ²	5	70mm ²	or	2	25mm x 3mm HCL515
16mm(5/8") - 19mm(3/4")	2	95-120mm ²	-	-	HCL516

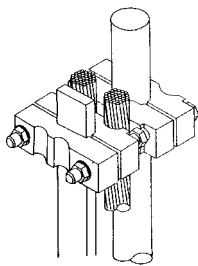

HCL504



HCL516



HCL507

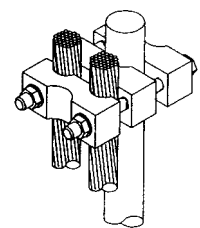

HC403

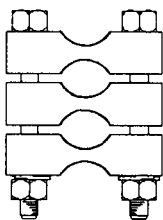

HC401/2



HC404

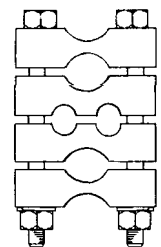

HCL514

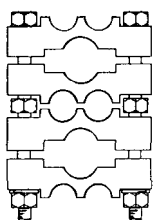

HCL513

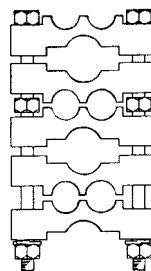

HCL515

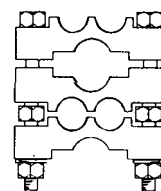

HCL516



HCL506S



HCL506

* Other combination can be supplied on request.

EARTHING

BOND & CLAMP

Watermain Pipe Bond

Max. Tape Width	Conductor Material	Part No
26mm	Copper	WMB26
26mm	Aluminium	WMB26A

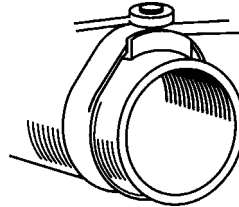

Bar Bond

Max. Tape Width	Bolt Size	Conductor Material	Part No
26mm	M10	Copper	BB26
26mm	M10	Aluminium	BB26A
31mm	M10	Copper	BB31

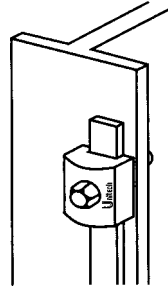

Rain Water Pipe Bond

Max. Tape Width	Bolt Size	Conductor Material	Part No
26mm	M10	Copper	RWP26
26mm	M10	Aluminium	RWP26A

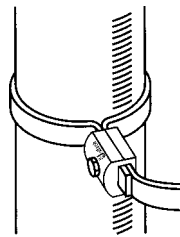

Flexible Copper Braid Bond

(For bonding gates, doors or fences)

Type	Part No
Flexible Earthing Straps	FES101
Flexible Connections with Tubes	FES102

* Overall braid dimensions 25mm x 3.5mm.
Length & hole sizes made to order.

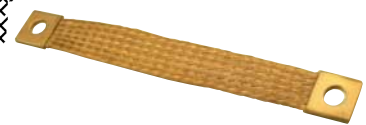
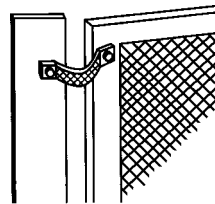

Tower Earth Clamp

(For Bonding Copper Cable To Steel Bar)

Conductor Dia	Bolt Size	Conductor	Part No
16-70mm ²	M10	Copper	TEC16*
16-70mm ²	M10	Tinned Copper	TEC16T*
25-50 mm ²	M10	Copper	TEC25*
25-50 mm ²	M10	Tinned Copper	TEC25T*
25-50 mm ²	M10	Aluminium	TEC25A*
70-120mm ²	M12	Copper	TEC70
70-120mm ²	M12	Tinned Copper	TEC70T
120-185mm ²	M12	Copper	TEC120
185-240mm ²	M12	Copper	TEC185

* Suitable for use with 8mm² solid circular conductor

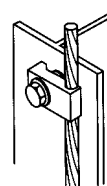
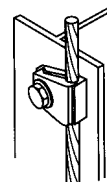

EARTHING

BOND & CLAMP

Earthing Receptacle (For Boats and Trucks)

Rod Dia	Part No
16mm (5/8")	EB58
19mm (3/4")	EB34

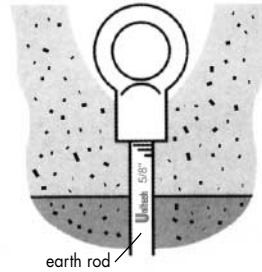

Static Earth Receptacle (For Aircraft, Fuel Tankers)

Conductor Material	Part No
Copper	SER10

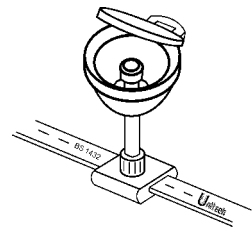
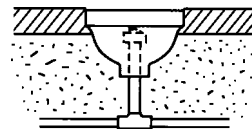

High Strength Connector

L	M	H	S	Part No
20mm	M17x2.5mm	6mm	18mm	HSC20
27mm	M19x2.5mm	7mm	20mm	HSC27
35mm	M21x2.5mm	7mm	22mm	HSC35
42mm	M23x2.5mm	11mm	24mm	HSC42
45mm	M25x2.5mm	14mm	26mm	HSC45
60mm	M29x2.5mm	17mm	30mm	HSC60
62mm	M31x2.5mm	20mm	32mm	HSC62

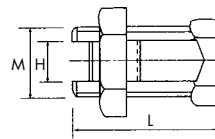
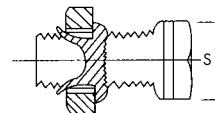

C-Connector

Conductor Size	H	B	L	C	Part No
25-35mm ²	25mm	15mm	22mm	10mm	CC25
50-70mm ²	34mm	21.5mm	25mm	11mm	CC50
95mm ²	41mm	25mm	29mm	14.5mm	CC95
120mm ²	47.5mm	29mm	30mm	16mm	CC120

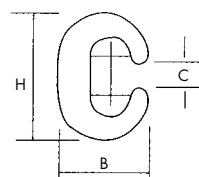
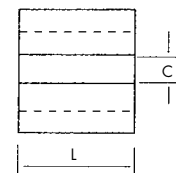

EARTHING

EARTH PLATE & PIT

Earth Plate - Solid Copper

Size (mm ³)	Part No
600 x 600 x 1.5	EPS661
900 x 900 x 1.5	EPS991
1200 x 1200 x 1.5	EPS221
600 x 600 x 3	EPS663
900 x 900 x 3	EPS993
1200 x 1200 x 3	EPS223
600 x 600 x 6	EPS666
900 x 900 x 6	EPS996
1200 x 1200 x 6	EPS226

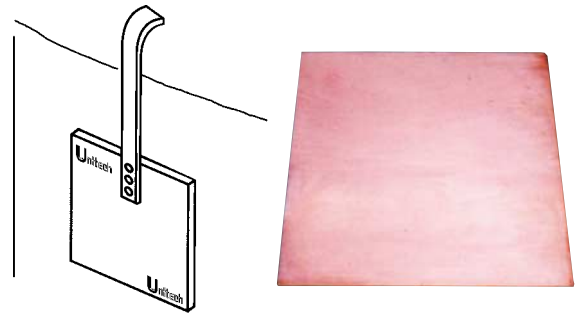

Earth Mat - Copper Tape

Size	Part No
600 x 600 x 3mm	EPL663
900 x 900 x 3mm	EPL993
1200 x 1200 x 3mm	EPL223
600 x 600 x 6mm	EPL666
900 x 900 x 6mm	EPL996
1200 x 1200 x 6mm	EPL226

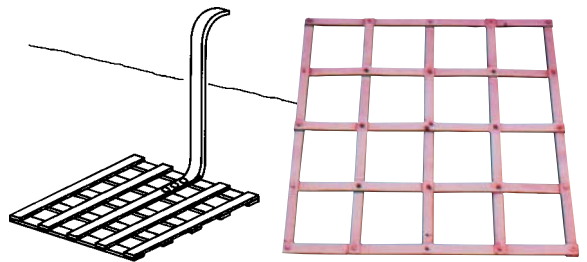

Concrete Inspection Pit

Type	Material	Part No
Square	Concrete	CIP10S
Round	Concrete	CIP10R

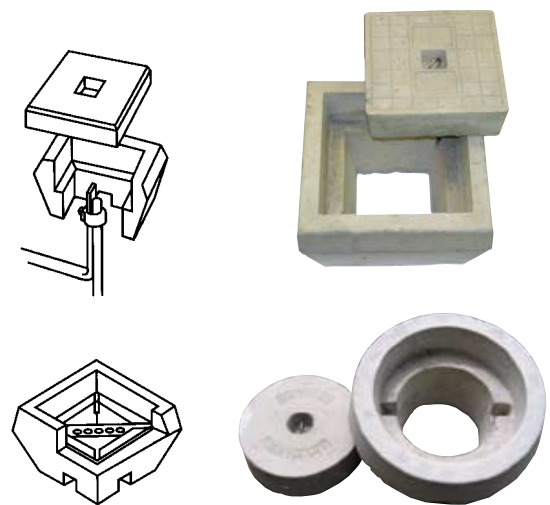

EARTHING

WATER SEALING GLAND

Water Sealing Gland

Type	Part No
Top Water Sealing Gland	WPS - 1A
Bottom Water Sealing Gland	WPS - 1B
Double Sealing Gland	WPS - 3
Heavy Duty Galvanized Steel Earth Pit	GSEP

TOP : Pressure tested to 200 PSIG

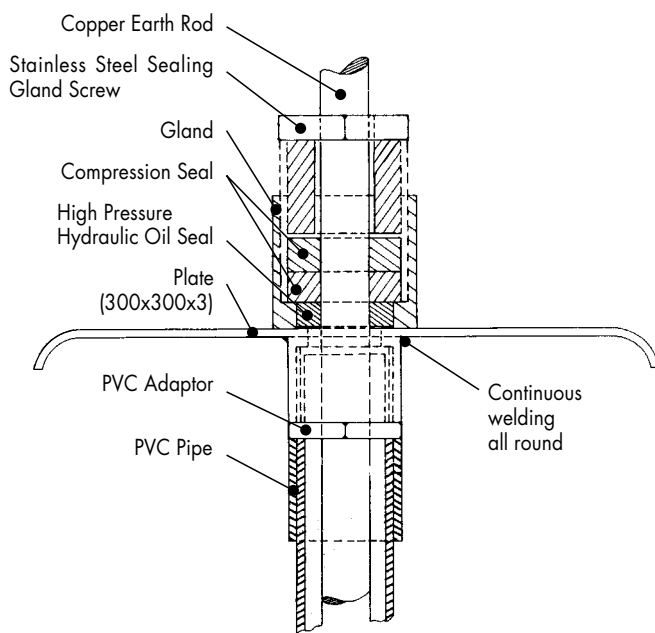

Galvanized Steel Earth Pit



Top Water Sealing Gland

BOTTOM

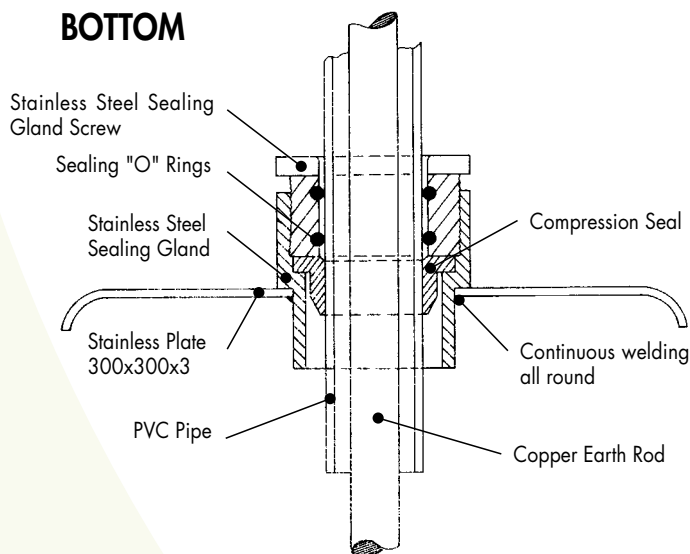

Double Sealing Gland

EARTHING

EARTH POINT

Four-Hole Earth Point

Hole size	Length	Material	Part No
M8 x 15mm	60mm	Copper	EP4
M8 x 15mm	60mm	Tinned Copper	EP4T

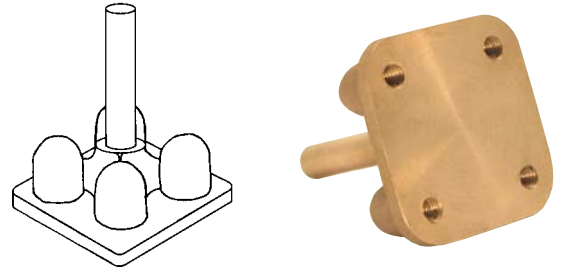

Four-Hole Earth Point with Cover Plate

Hole size	Material	Part No
M8	Copper	EPCP4
M8	Tinned Copper	EPCP4T

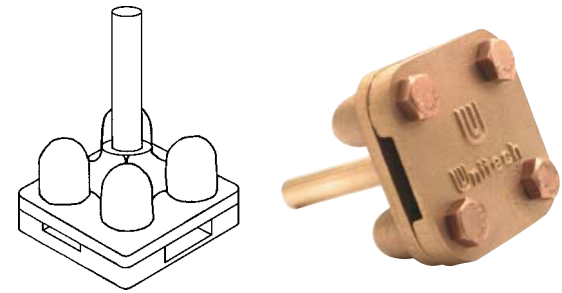

Two-Hole Earth Point

Hole size	Material	Part No
M8	Copper	EP2
M8	Tinned Copper	EP2T

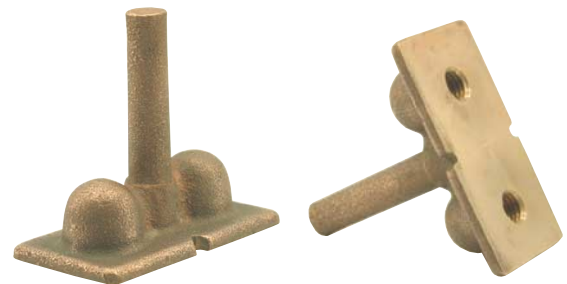

EARTHING

EARTH POINT

Copper Earth Point welded to Mild Steel Rod

Joint Type	Steel Rod Dia	Part No (Bare)	Part No (Tinned)
T Joint	10mm	EP4-10H	EP4-10HT
T Joint	16mm	EP4-16H	EP4-16HT
T Joint	20mm	EP4-20H	EP4-20HT
T Joint	25mm	EP4-25H	EP4-25HT
Straight Joint	10mm	EP4-10S	EP4-10ST
Straight Joint	16mm	EP4-16S	EP4-16ST
Straight Joint	20mm	EP4-20S	EP4-20ST
Straight Joint	25mm	EP4-25S	EP4-25ST

* Different lengths and sizes of mild steel rod (cable) available on request.

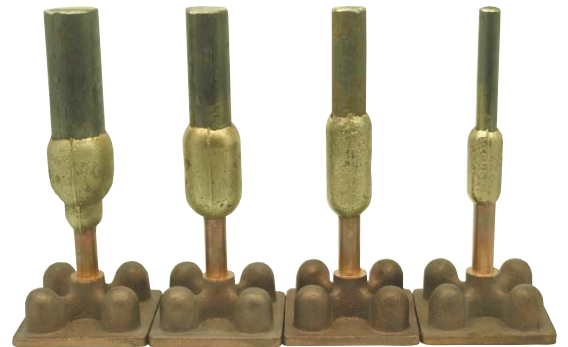
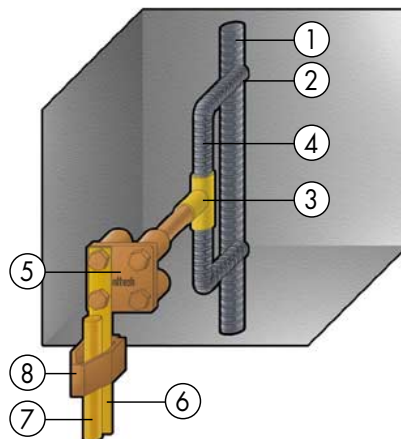
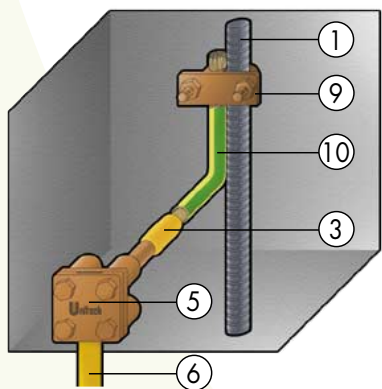
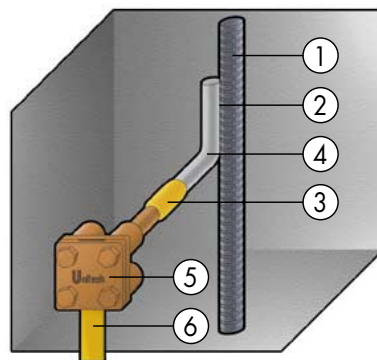
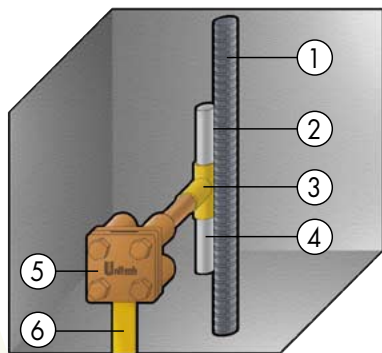

ILLUSTRATION OF COMMON DESIGNS AND INSTALLATIONS



1. reinforcement down conductor
2. arc welding
3. exothermic welding connection
4. mild steel bar
5. earth point
6. copper tape
7. earth rod
8. rod to tape A Clamp
9. rod to cable U Clamp
10. yellow/green cable

EARTHING

EARTHING TERMINAL AND ACCESSORIES

Insulator

Tensils Strength(1bs)	Torgue Strength(ft 1bs)	Voltage withstand	Screw	Weight	Part No
500	6	6kv	6mm	28g	IN10
550	8	8kv	8mm	44g	IN20
600	10	10kv	8mm	50g	IN30
650	10	12kv	8mm	86g	IN40
1000	20	15kv	8mm	83g	IN50
1500	40	25kv	10mm	233g	IN60



Earth Bar and Disconnecting Link

Type	Length	Width	Height	Part No
Disconnecting Link	125mm	90mm	90mm	EBD125
Six Way Earth Bar	450mm	90mm	90mm	EBD450
Six Way Earth Bar with Twin Disconnecting Link	650mm	90mm	96mm	EBD650
Six Way Earth Bar with Single Disconnecting Link	575mm	90mm	96mm	EBD575

* Number of ways and disconnecting links available on request.

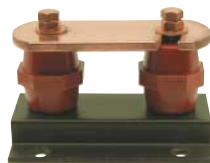
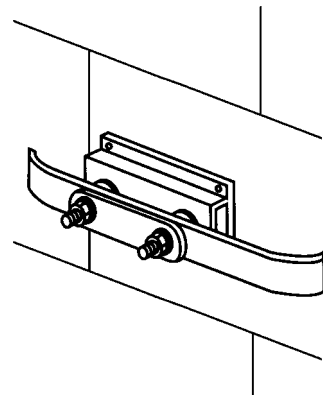

EBD125

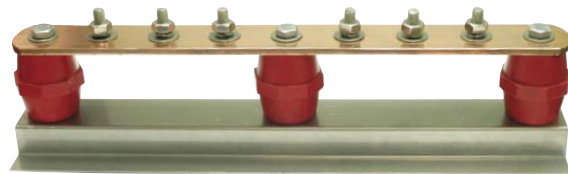

EBD450

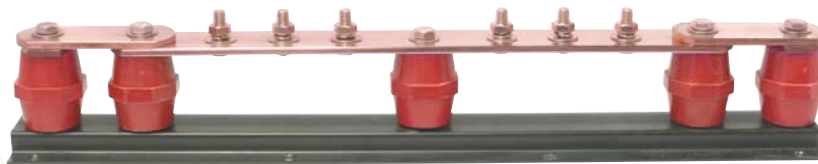

EBD650

EARTHING

CONDUCTIVE CONCRETE

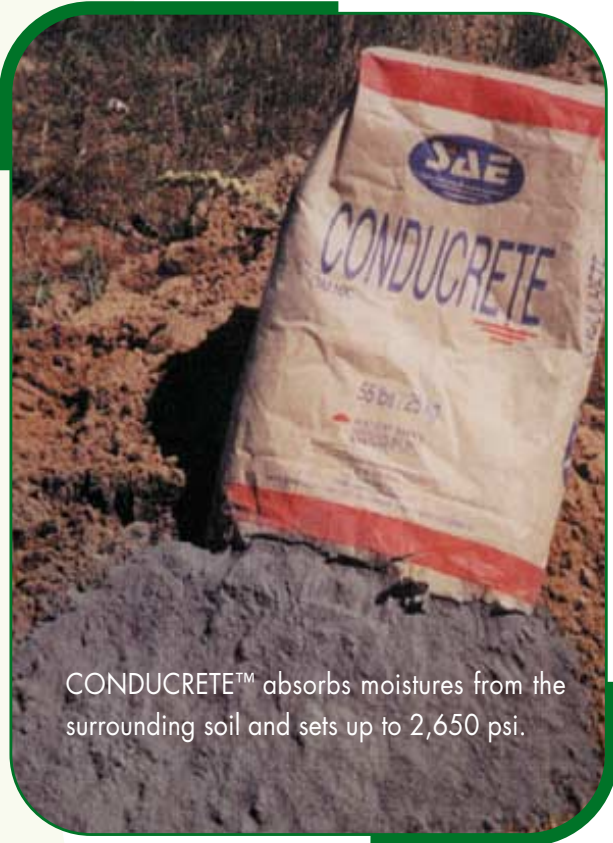

CONDUCTRETE™ absorbs moisture from the surrounding soil and sets up to 2,650 psi.

CONDUCTRETE™ is a conductive cementitious product used in the construction of ground electrodes.

For horizontal or vertical installations, CONDUCTRETE™ electrodes offer superior performance.

CONDUCTRETE™ electrodes are:

- Permanent and maintenance free,
 - Cost effective,
 - Easy to install,
 - Environmentally safe,
 - Suitable for all terrain.
-
- CONDUCTRETE™ is highly capacitive and, as a result, CONDUCTRETE™ electrodes are an excellent absorber of high rise time surges.
 - CONDUCTRETE™ electrodes have a larger conductive surface area than conventional systems and therefore, lower surge impedance and ground resistance.
 - CONDUCTRETE™ reduces copper conductor electrolytic corrosion by up to 90%.
 - CONDUCTRETE™ electrodes have far less seasonal R value fluctuations than conventional systems.
 - CONDUCTRETE™ electrodes are virtually theft proof.

CONDUCTRETE™ INSTALLATIONS

Horizontal Electrodes

Vertical Electrodes



EARTHING

EQUIPMENT



DET5/4R and 5/4D

Four-Terminal Ground Resistance Tester

- Simple, fully automatic operation
- Choice of three- or four-terminal measurement
- Autoranging from 10mΩ to 20kΩ



DET 2/2

Auto Earth Tester

- High resolution - 1mΩ - ideal for large earthing systems
- High accuracy for earth electrode and soil resistivity testing
- Test voltage 50V max. for safety
- Rechargeable battery power with long battery life and rapid re-charge
- A robust, versatile instrument with IP54 protection
- Filter and high current features to enable valid earth testing in difficult situations



DET62D

Three-Terminal Ground Resistance Tester

- Simple, fully automatic operation
- Three terminal measurement for ground electrode testing
- Superior noise rejection to 40V
- High tolerance to spike resistance
- Weatherproof case, protection to IP54



MK1

Earth Rod Hammer

- Hard-hitting, 60-joule performance
- Ideal for medium-duty applications
- Low vibrations
- User-friendly
- Easy to maintain and service
- Comprehensive range of tools and accessories

EXOTHERMIC WELDING

The thermOweld electrical connection process is a simple, efficient method of welding copper to copper or copper to steel. No outside source of power is required when using thermOweld. thermOweld connections use the high temperature of reaction of powdered copper oxide and aluminium. The reaction takes place in a semipermanent graphite mold (thermOweld) that lasts for fifty or more welds if properly cared for. The thermOweld reaction takes place in a very few seconds, therefore the total amount of heat (calories or BTU's) applied to the conductors or surfaces is considerably less than that employed in brazing or soldering. This is an important consideration when welding to insulated cable or thin wall pipe.

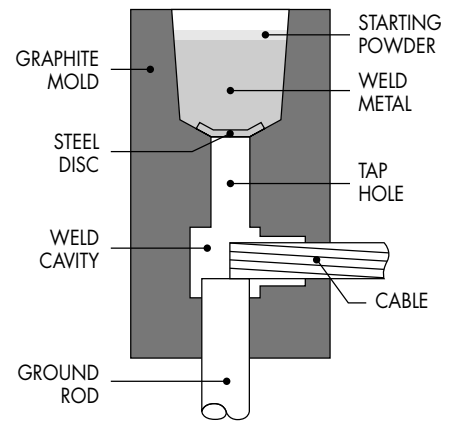

thermOweld is ideal for field use, since it is light and portable and requires no outside power source. It requires very little time or skill to obtain an efficient, maintenance free electrical connection when using thermOweld.

thermOweld equipment required for making all types of electrical connections are shown on the following pages.

thermOweld CONNECTION

The thermOweld connection is a molecular weld. The weld metal has same melting point as copper. Because of these factors along with the increased cross section of the connection, ThermOweld connections:

1. Will not be affected by a high current surge. Tests have shown that the electrical conductor will melt before the thermOweld connection when subjected to high short-circuit current. Consult I.E.E.E. Standard 80-1989.
2. Will not loosen or corrode at the point of weld. There are no contact surfaces or mechanical pressures involved. A thermOweld connection becomes an integral part of the conductors.
3. Have a current - carrying capacity equal to or greater than that of the conductors.

thermOweld equipment has been used to weld materials other than copper for electrical purposes. Materials welded have included:

Stainless Steel	Monel	Copper Clad Steel	Steel Rail	Brass
Copperweld®	Plain Steel	Bronze	Chromax	Nichrome
Nichrome V	Everdur® ¹	Galvanized Steel	Wrought Iron	Cast Iron
Kama	Cor-Ten® ²	Silicone Bronze	Columbium	Niobium

1 Anaconda Copper Co. 2 United States Steel Corp.

When welding to galvanized steel it may be necessary to resurface exposed bare steel.

EXOTHERMIC WELDING

MAKING A THERMOWELD CONNECTION



Mold & Accessories



1 Position cleaned conductors in mold after making sure mold is dry, by pre-heating or making a test joint.



2 Place metal disc in bottom of mold crucible.



3 Dump powder into crucible, spreading some starting powder on edge of mold.



4 Close lid and ignite with flint gun from side, firing spark onto the starting powder.



5 Reaction takes place.



6 Remove weld and clean mold before making next connection.

EXOTHERMIC WELDING

thermOweld PREFABRICATED WIRE MESH

Grounding • Personal Safety Mats • Equipotential Planes • Signal Reference Grid

The prefabricated wire mesh is a convenient, efficient and economical means of improving grounding systems at **facilities where large area grounds are required.**

No expensive, special equipment is necessary. The strong, pliable mesh is simply unrolled over the ground, **interconnected using parallel type exothermic welded connections** to attach adjacent sections of mesh, and to main ground grid or ground rods. The mesh maybe covered with a layer of earth or crushed stone.

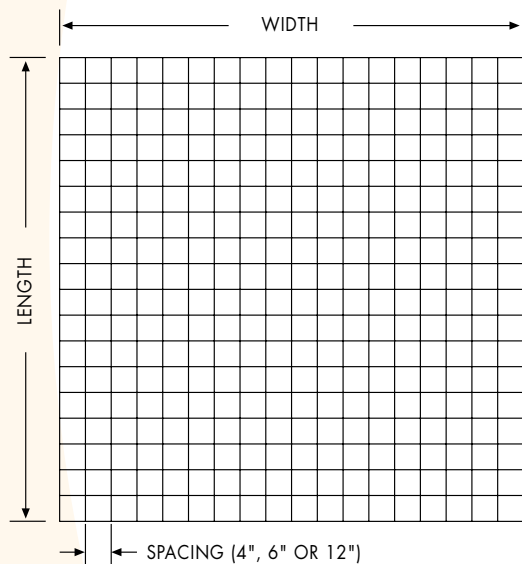

PREFABRICATED WIRE MESH IS:

- Manufactured from bare solid copper or copperclad conductors
- Spaced on 4", 6" or 12" centers
- Silver brazed at each crossover using 35% silver and a non-corrosive flux
- Furnished in sections with widths from 2 feet to 18 feet
- Shipped on tubes and protected for transporting
- Interconnected in the field using exothermic welded connections

Molds for Connecting Prefabricated Wire Mesh

Wire Size	Weld Type	Mold#	Price Key	Handle Clamp	Weld Metal
#6 Sol Copper	CC-14	M-6205	18	40-4565-0	#25
#6 Sol Copperweld	CC-14	M-6207	18	40-4565-0	#15
#8 Sol Copper	CC-14	M-6209	18	40-4565-0	#15
#8 Sol Copperweld	CC-14	M-6210	18	40-4565-0	#15
#10 Sol Copper	CB-34	M-6211	18	40-4565-0	#15
#10 Sol Copperweld	CB-34	M-6212	18	40-4565-0	#15

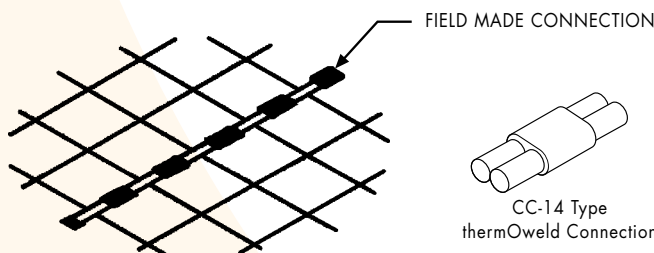

Adjoining sections of mesh are to be exothermically welded by installer using thermOweld molds and powder.

EXOTHERMIC WELDING

BUS BAR TO BUS BAR

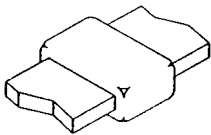

BB-7
Horizontal Splice
Bars Flat

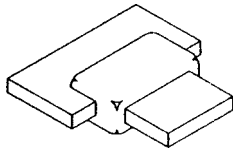

BB-14
Horizontal Tee
Bars Flat

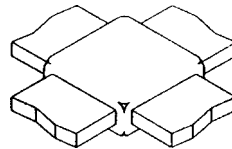

BB-40
Horizontal Cross
Tap Cut / Bars Flat

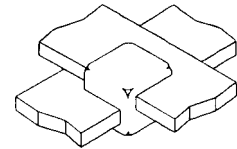

BB-41
Horizontal Cross
Bars Uncut / Bars Flat

CABLE TO CABLE

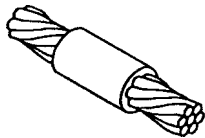

CC-1
Splice / Horizontal

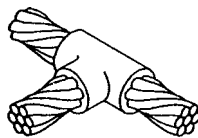

CC-2
Tee / Horizontal

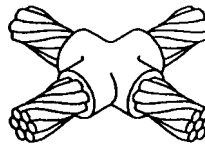

CC-4
Cross (X) / Horizontal
Tap Cable Cut

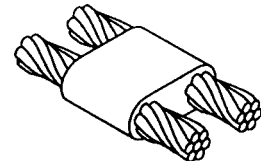

CC-14
Parallel / Horizontal
Run & Tap (Side-by-Side)

BUS BAR TO GROUND ROD

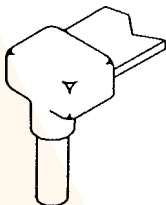

BR-1
Horizontal Bar Dead End
Bar Flat

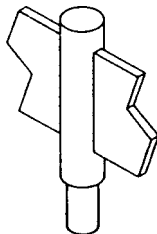

BR-2
Horizontal Bar Thru
Bar On Edge

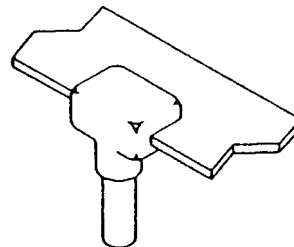

BR-7
Horizontal Bar Thru
Bar Flat

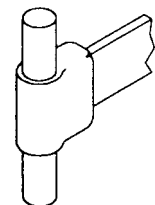

BR-8
Horizontal Bar
Bar On Edge

EXOTHERMIC WELDING

CABLE TO GROUND ROD

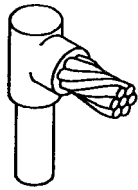

CR-1
Horizontal Cable Dead
End Vertical Ground Rod

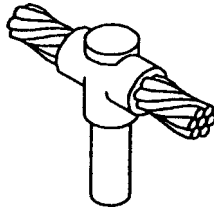

CR-2
Horizontal Cable Thru
Vertical Ground Rod

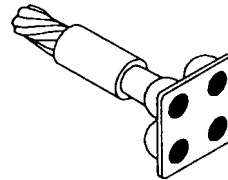

CR-27
Horizontal Cable
Horizontal Ground Plate

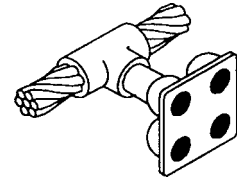

CR-30
Horizontal Cable Thru
Horizontal Ground Plate

GROUND ROD TO GROUND ROD



RR-1
Splice / Vertical

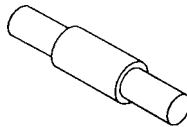

RR-2
Splice / Horizontal

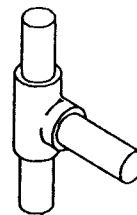

RR-3
Vertical Thru /
Horizontal Tap

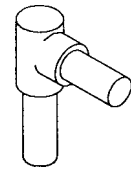

RR-4
Horizontal Tap /
Vertical Down

CABLE TO LUG OR BUS BAR

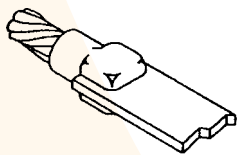

CB-1
Horizontal Cable
Horizontal Lug or Bus Bar

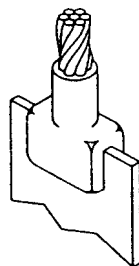

CB-2
Vertical Cable Up
Vertical Bus Bar Down
over 5" clearance behind

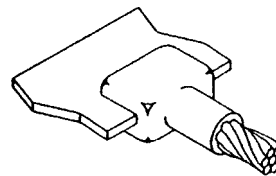

CB-4
Horizontal Cable
Horizontal Bus Bar

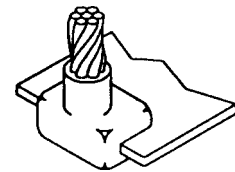

CB-23
Vertical Cable Up
Horizontal Bus Bar

EXOTHERMIC WELDING

CABLE TO REBAR

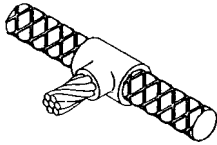

CRE-2
Tee / Horizontal Cable
Horizontal Rebar

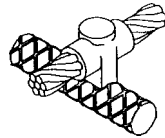

CRE-4
Cross / Horizontal Cable
Thru / Horizontal Rebar



CRE-7
Splice / Vertical Cable Up
Vertical Rebar Down



CRE-20
Parallel / Vertical Cable
Thru / Vertical Rebar Thru

CABLE TO RAIL

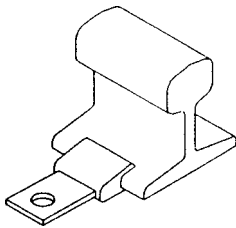

BX-2
Horizontal Bar Tap
To Rail Foot

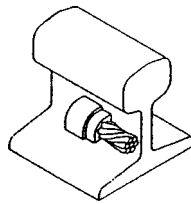

CX-1
Horizontal Tap
To Rail Fillet

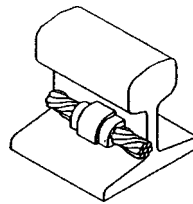

CX-2
Horizontal Thru
To Rail Fillet

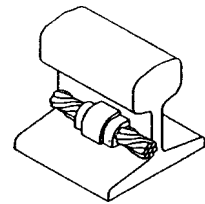

CX-11
Parallel / Horizontal Thru
To Web of Rail

CABLE TO AIRCRAFT GROUNDING RECEPTACLE



AC-2
Horizontal Cable Thru
Aircraft Receptacle

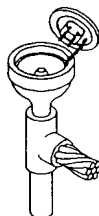

ACR-1
Cable / Aircraft Grounding
Receptacle / Ground Rod



ACR-2
Cable Thru / Aircraft
Grounding Receptacle /
Ground Rod

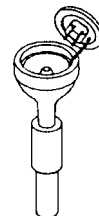

AR-1
Aircraft Grounding
Receptacle / Ground Rod

SURGE PROTECTION

Why Install Surge Protection?

In today's technology-driven business, large areas of industry and commerce are dependent on Electronic and Electrical Technology. Electronic data processing, telecommunications, instrumentation and electrical power control equipment can be found in most companies.

The consequences of an unexpected power surge can be catastrophic to any business or facility. Modern equipment is costly to repair, although this can be insignificant when compared to the secondary costs resulting from equipment down time, lost production and the huge costs involved in correcting and reinstating corrupt data and systems.

Additionally, personnel may be placed at undue risk through the possible failure of safety systems.

Surge Protection of Mains Power

All mains power lines entering or leaving a building are prime routes for lightning and switching-induced surges and transient over-voltages to enter the electrical and electronics systems. Due to the large cross sectional area of these cables, high current and voltage surges can enter with minimum attenuation.

By installing Unitech Surge Protection devices in shunt with the incoming mains, surges and over-voltages can be reduced to an acceptable level. Unitech Surge Protection devices are available for single and three-phase installations.

U-B20/2

For use on 1-phase & 3-phase 230v/440v networks	Single phase
Nominal voltage	400V
Response time	<25ns
Operating temperature	<90%
IP value	Ip20
Number of 17.5mm modules (width)	4
Protection mode	TN
Max. continuous operating voltage (Uc) =	320V
Nominal discharge current (20 times) 8/20 wave	20kA
Max. discharge current (once) 8/20 wave	40kA
Protection level	1.2kV
Internal short circuit withstand current	10A
Follow current	<10 μ A
Built-in thermal disconnection	Yes
Visualization of arrester status under no voltage condition	Yes
Terminal wire gauge	Ph/N: flexible wire 16mm ² to rigid wire 25mm ² \perp : flexible wire 35mm ² to rigid wire 50mm ²
Operating temperature	-40.C to -85.C
Standard complied	IEC61312-3
Remote indicator	Yes



SURGE PROTECTION

U-B20/3+NPE

For use on 1-phase & 3-phase 230v/440v networks	Three phase
Nominal voltage	400V
Response time	<100ns
Operating temperature	<90%
IP value	Ip20
Number of 17.5mm modules (width)	4
Protection mode	TN
Max. continuous operating voltage (Uc) =	520V
Nominal discharge current (20 times) 8/20 wave	20kA
Max. discharge current (once) 8/20 wave	40kA
Protection level	1.5kV
Internal short circuit withstand current	10A
Follow current	<10 μ A
Built-in thermal disconnection	Yes
Visualization of arrester status under no voltage condition	Yes
Terminal wire gauge	Ph/N: flexible wire 16mm ² to rigid wire 25mm ² ⚡: flexible wire 35mm ² to rigid wire 50mm ²
Operating temperature	-40.C to -85.C
Standard complied	IEC61312-3
Remote indicator	Yes



U-B20/4

For use on 1-phase & 3-phase 230v/440v networks	Three phase
Nominal voltage	400V
Response time	<25ns
Operating temperature	<90%
IP value	Ip20
Number of 17.5mm modules (width)	4
Protection mode	TN
Max. continuous operating voltage (Uc) =	520V
Nominal discharge current (20 times) 8/20 wave	20kA
Max. discharge current (once) 8/20 wave	40kA
Protection level	1.2kV
Internal short circuit withstand current	10A
Follow current	<10 μ A
Built-in thermal disconnection	Yes
Visualization of arrester status under no voltage condition	Yes
Terminal wire gauge	Ph/N: flexible wire 16mm ² to rigid wire 25mm ² ⚡: flexible wire 35mm ² to rigid wire 50mm ²
Operating temperature	-40.C to -85.C
Standard complied	IEC61312-3
Remote indicator	Yes



SURGE PROTECTION

Surge Protection of Data, Signal & Telecommunications

With the increasing sophistication of today's electronic systems, the need for reliable, uninterrupted operation is essential. The effect of a lightning-induced surge or over-voltage entering any of these systems can be catastrophic both from the view of equipment repair costs, data corruption, component damage, operational down-time, loss of revenue, customer dissatisfaction and risk to human safety.

By installing Unitech Data, Signal & Telecommunications Protection devices in series with all incoming data, telecommunications, instrumentation, industrial process control lines, coaxial cable, computer networks and digital data circuits, surges and over-voltages can be reduced and effectively controlled.

Unitech manufactures a complete range of Surge Protection devices to meet the protection needs of low DC voltage systems.

All devices are designed to provide maximum protection without affecting the performance or quality of the signal.

Further information on the complete range of Unitech Surge Protection devices are available. Please contact your local distributor or visit us at www.earthingsolution.com

U-PHS-P/S40

Protection for power lines

Installation	Parallel
Max. permanent operating voltage (U_c) =	350V
Nominal voltage (U_n)	250V
Nominal discharge current	40kA
Residual voltage	<600V
Response time	<25ns

Protection for signal lines

Installation	Series
Connector type	RJ11/RJ45
Nominal Voltage (U_n)	200V
Nominal discharge current	10kA
Max. discharge current	20kA
Protection level	<200V
	<250V
Band width	20Mbps
Response time	<0.5ns
In-line resistance	<1 Ω
Insertion loss	<0.1 db
Temperature	- 40°C to -85°C
Relative	<90%
Dimensions	280 x 200 x 80mm ³



OTHER PRODUCTS



The Braids



Flexible Connections for Aircraft Industry

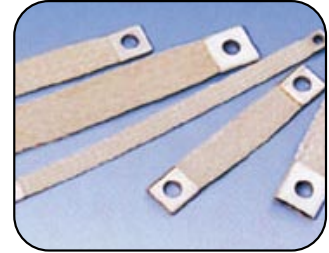

Flexible Earthing Straps

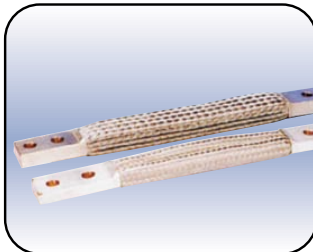

Flexible Connections with Tubes

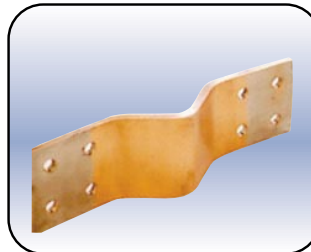

Connection in Strip

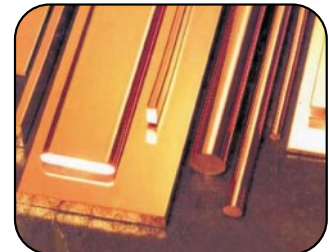

Bus Bars



Preformed Components



Lightning Strike Counter

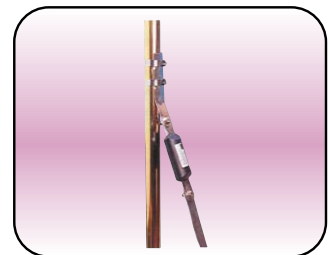

Surge Divvester



Equipotentiality Bars

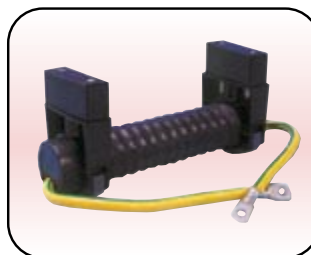

Ground Coil

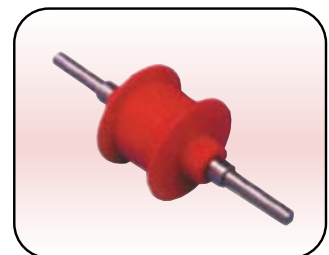

Equipotentiality Surge Divvester

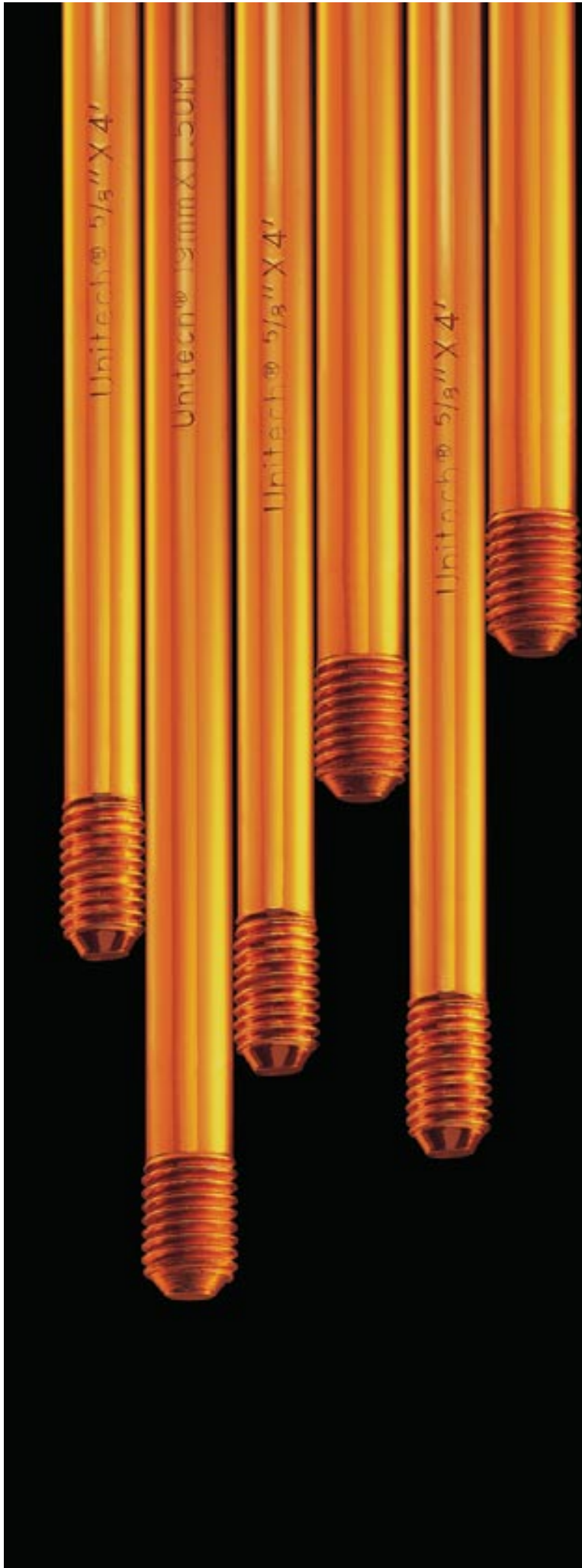

Unitech Electric & Lightning Technologies Limited

Flat 12, 20/F., Metro Centre II, 21 Lam Hing Street,
Kowloon Bay, Hong Kong

Tel (852) 3110 2220 Fax (852) 3110 2397

e-mail: Sales@earthingsolution.com website: www.earthingsolution.com

Singapore Address:

11 Senoko Avenue

Woodlands East Industrial Estate

Singapore 758301

Tel: 65-6758 1111 Fax: 65-6758 9007

e-mail: uniteche@singnet.com.sg